

**CITY OF ROSEVILLE
DEPARTMENT OF PUBLIC WORKS**

**CONSTRUCTION
STANDARDS**



MAY 2001

SECTION 71 STREETS

71-1	General	ST-1
71-2	Connection to Existing Improvements	ST-1
	A. Existing Stub Street Connection	ST-1
	B. Street Widening	ST-1
71-3	Construction Staking	ST-1
71-4	Installation	ST-2
	A. Subgrade	ST-2
	B. Aggregate Base and Subbase	ST-3
	C. Concrete	ST-5
	D. Asphalt Concrete Paving	ST-10
	E. Sound and Retaining Walls	ST-12
	F. Survey Monuments	ST-12
	G. Street Barricades	ST-13
	H. Pavement Removal	ST-13
	I. Utility Boxes	ST-13
71-5	Materials	ST-13
	A. Aggregate Base and Subbase	ST-13
	B. Concrete	ST-13
	C. Asphalt Concrete	ST-13
	D. Lime/Fly Ash or Cement Treated Subbase	ST-15
	E. Truncated Domes	ST-15
	F. Graffiti Coating	ST-15
	G. Epoxies, Patching Material	ST-15
	H. Reinforcement Bar	ST-16
	I. Concrete Curing Compound	ST-16

STREETS DETAILS

Type 1 and 2 Curb and Gutter with Sidewalk	ST-1
Barrier Curbs and Valley Gutter	ST-2
Residential Curb Ramp Case C	ST-3
Residential Curb Ramp Case C (Detached Sidewalk)	ST-4
Case E Curb Ramps Collector/Industrial/Arterial Streets	ST-5
Type A-7 Commercial Driveway	ST-6
Right Turn Curb Flare for A-7 Driveway or Paved Entry	ST-7
Type S Commercial Driveway	ST-8
Residential/Commercial Driveway, Type D	ST-9
Bus Turnout Concrete Slab	ST-10
Bus Stop Shelter Pad	ST-11
Traffic Island Detectable Warning Surface	ST-12
Street Closure Timber Barricade	ST-13
Sidewalk Barricade	ST-14
Boxed Survey Monument	ST-15
Under Walk Drain	ST-16

Typical Traffic Control Lane Closure/Transition	ST-17
Detectable Warning (Truncated Dome Panel) Retrofit or Replacement	ST-18

SECTION 81 DOMESTIC WATER SUPPLY SYSTEM CONSTRUCTION

81-1	General	W-1
81-2	Connection to Existing Facilities	W-1
81-3	Construction Staking	W-2
81-4	Earthwork	W-2
81-5	Dewatering	W-3
81-6	Pipe Bedding	W-3
81-7	Concrete Cradles, Arches & Encasements	W-3
81-8	Pipe Zone Backfill	W-4
81-9	Pipe Installation	W-4
81-10	Service Installation	W-9
81-11	Abandonment of Services and Mains	W-10
81-12	Appurtenances Installation	W-10
81-13	Testing Procedures	W-11
81-14	Repairing Installed Improvements	W-14
81-15	Punchlist Process	W-15
81-16	Materials	W-15

METER APPLICATION TABLE	TABLE 1
--------------------------------	----------------

WATER DETAILS

Water Main Trench & Backfill	W-1
Fire Protection Assembly	W-2
Onsite Fire Protection	W-3
2" Blowoff Hydrant Assembly	W-4
Residential ¾" Inch Service Line	W-5
Commercial ¾" & 1" Service Line	W-6
Commercial 1 ½" & 2" Service Line	W-7
Commercial 3" & Larger Service	W-8
Commercial 1 ½" & 2" Irrigation Service	W-9
Water Service Box Location	W-10
Sampling Station	W-11
1" and 2" Air Release Valve Assembly	W-12
Fire Hydrant Assembly	W-13

SECTION 71

STREETS

71-1 GENERAL -- Street surface improvements shall include: barricades, bikeways, bridges, bollards, curb, curb & gutter, driveways, pavement, curb ramps, sidewalk, survey monuments and tunnels. These improvements shall be installed in accordance with the approved improvement plans, these Construction Standards and the latest edition of The State of California Department of Transportation Standard Specifications hereinafter referred to as the Caltrans Standard Specifications (the latest edition which specifies the U.S. Customary Units of ounces and inches, currently 1992) and as specified by the City Engineer. No street shall be cut, nor any public improvement disturbed until the Developer/Contractor has obtained an encroachment permit from, and/or entered into a subdivision agreement with the City.

71-2 CONNECTION TO EXISTING IMPROVEMENTS -- Connection to existing surface improvements require that the following conditions be met:

- A. Existing Stub Street Connection** -- The Developer shall be responsible for removing and reconstructing a portion of the existing roadway to make a satisfactory connection, as required by the City Engineer.
- B. Street Widening** -- When widening to complete a partial street along a development project, the Developer shall be responsible for saw cutting and removing a narrow strip along the outside portion of the pavement to provide a clean and stable pavement section for constructing against. The width from centerline shall be shown on the approved plans or as determined in the field, and verified by the City Engineer. Following construction of the adjacent curb and gutter, paving shall not commence until the Public Works Inspector is satisfied that the crossgrade between the existing pavement edge and the new gutter lip conforms to or approaches the City's required 2% crossgrade. 4% is the maximum crossgrade allowed on this AC pavement section unless shown on the approved plans.

71-3 CONSTRUCTION STAKING -- Construction staking shall be provided by the Developer for all surface improvements. Such staking shall provide the station and offset, as well as the cut to the nearest hundredth (0.01) of a foot. Stakes shall be provided at a minimum of every 50 feet in tangent sections and every 25 feet in curved sections. Monuments shall have straddle ties placed.

Cut sheets for the appropriate phase of work shall be on-site and shall be furnished to the Public Works Inspector upon request.

The grades and locations for the top and bottom of slope for all curb ramps shall be staked by the engineer's surveyor.

71-4 INSTALLATION --

A. Subgrade -- Note: The geotechnical engineer shall closely monitor and test subgrade fills to assure the material meets soil R-Values identified in the street design portion of the project soils report. If R-Values differ from the soils report, structural sections shall be adjusted (including plan revisions) by the design engineer and approved by the City Engineer. Where mehrten (mehrten mudflow breccia and/or mehrten conglomerate), lava cap material, cobbles or other stable native subgrade materials are encountered upon commencement of street grading, the respective material may be substituted for processed subgrade, and/or aggregate subbase and/or aggregate base. This is conditional upon confirmation by the geotechnical and design engineers (and approval of the City Engineer) that the existing subgrade/subbase/base section thicknesses and composition will meet or exceed traffic index and R-Value requirements for the respective street. A minimum of three inches of Class II aggregate base shall be required on such substituted material on which to pave.

Soils testing for relative compaction shall reference ASTM D1557-78 test methods.

1. Subgrade for Sidewalk and Curb Ramps, Curb and Gutter, Driveways and Asphalt Concrete Paving -- Subgrade shall be processed to 95% relative compaction, minimum six inches plus, and shall be tested and certified by a geotechnical engineer, licensed in California. Written certification shall be provided to the Public Works Inspector prior to the placement of concrete (and aggregate base or aggregate subbase for asphalt concrete). For meandering sidewalks, 3/4 inch aggregate base may be substituted for native subgrade at the Contractor's discretion and shall be processed to 95% relative compaction.

Additionally, subgrade stability for curb, gutter and sidewalk and asphalt concrete pavement shall be load tested by proof rolling with a loaded, minimum 3,000 gallon water truck (or equipment of equivalent weight as approved by the Public Works Inspector) in the presence of the Public Works Inspector, the Geotechnical Engineer and the Contractor. The proof roll test shall be repeated following corrective measures. Prior to placement of aggregate base, deflection in the subgrade shall be eliminated. Placement of aggregate base shall not commence without the approval of the Public Works Inspector.

Where mehrten (mehrten mudflow breccia and/or mehrten conglomerate), lava cap material, cobbles or other native subgrade

material not conducive to the operation of the concrete extruding machine are encountered, that material shall be removed to a depth of six inches below top of subgrade, and shall be replaced with native or imported soil (acceptable to the Public Works Inspector and the geotechnical engineer) compacted as specified above.

Aggregate base is not included in the structural section for monolithic sidewalk and Type 1 (or Type 2) curb and gutter. Aggregate base may be used for meandering or otherwise detached sidewalk.

Sidewalk subgrade exposed upon removal of existing sidewalk shall remain intact unless it is determined by the Public Works Inspector to be unstable. In this event, it shall be processed per the preceding paragraphs.

Deflecting, unstable areas shall be corrected per the recommendation of the Geotechnical Engineer and upon the approval of the Public Works Inspector prior to placement of aggregate base, or concrete curb, gutter and sidewalk.

ORDER OF WORK: Street subgrade preparation, concrete placement and placement of any aggregate base or subbase for asphalt concrete pavement within the City right-of-way shall conform to the following sequence of operations, notwithstanding Section B. below. Prior to placement of aggregate base in the City right-of-way, the contractor shall:

- a. Complete underground work outlined in Section B. below.
- b. Process and compact subgrade for curb, gutter, sidewalk and asphalt concrete pavement, back of sidewalk to back of sidewalk.
- c. Complete construction of curb, gutter and sidewalk after approval of the subgrade by the Public Works Inspector.
- d. Complete finish grading of subgrade for asphaltic concrete pavement, conduct proof rolling test and begin placement of aggregate subbase and/or aggregate base after approval of the finished subgrade by the Public Works Inspector.

B. Aggregate Base and Subbase -- Roadway aggregate base and subbase, sidewalk, curb and gutter shall not be placed until the following items of construction within the City street right-of-way are completed:

1. Installation of underground sewer and water systems and testing or televising, and approval of same by the EUD Inspector.

Completion of testing for the presence of bacteria and the water system tie-in shall not be requirements for the approval of commencement of surface improvement construction. However, the water main tie-in shall be completed prior to asphalt concrete paving. The Contractor shall schedule operations such that the curb, gutter and sidewalk pour shall not be conducted on the same day as the water tie-in.

2. Installation, mandrelling of the non-rigid underground storm drain pipe and dry utility conduit crossings and approval of same by the Public Works Inspector.
3. Installation of electric, natural gas, telephone, traffic signal (including interconnect) and cable TV, including mandrelling and testing of conduits, installation of 4x4 markers a minimum of two feet high, painted red, buried at the crossing ends (if conduit ends do not extend up from finish grade). This includes all dry utility crossing and longitudinal trenches.
4. Backfill and compaction testing of all trenches related to the above and approval of same by the Public Works Inspector.

All aggregate base and subbase (AB and ASB) shall be installed per provisions in Sections 25 and 26 of the Caltrans Standard Specifications. AB and ASB shall be compacted to 95% relative compaction. An oil seal is not required on the AB surface. If required by the Public Works Inspector, AB and ASB shall be tested for compaction and approved by geotechnical engineer, licensed in California. It shall be proof rolled as specified in Section 71-4, 2. above if requested by the Public Works Inspector. Written certification of compliance to these requirements shall be provided to the Public Works Inspector.

Aggregate base shall be installed as a base for asphalt concrete paving where specified on the approved plans unless lime and fly ash or cement treatment is used.

Aggregate base in any thickness determined by the contractor may be used for meandering sidewalk wherever that sidewalk is not connected to the back of curb, or as a base for A-7 driveways outside the sidewalk at the curb returns. All aggregate base shall be compacted to 95%.

Where lone valley gutters are placed within the City pavement as in an alley, the aggregate base section for the gutter shall extend to the same depth as the aggregate base section for the adjacent asphalt concrete pavement.

Prior to paving, deflection in the compacted aggregate base shall be eliminated. Paving shall not commence without the approval of the Public Works Inspector.

- C. Concrete** -- All concrete curbs, curb & gutters, sidewalks, curb ramps, driveways, bus stop pads and turnouts shall be installed per provisions in Section 73 of the Caltrans Standard Specifications, Construction Standard Details ST-1 through ST-12 and ST-18 and the following provisions:

- 1. Thickness** -- All residential and commercial sidewalk shall be six inches thick. Across commercial driveways, the concrete section shall be eight inches with grade 60, #4 rebar, 18 inches on center each way, conforming to the Construction Standard Details.

All commercial driveways, and bus turn-outs shall be 8 inches thick, with number 4, grade 60 rebar, on 18 inch centers each way. Rebar shall be set on 3 inch concrete dobies/rebar supports at three foot maximum spacing each way. The dobies shall include wire ties. See the Construction Standard Details.

Base for commercial driveways may be processed native subgrade or 3/4 inch aggregate base compacted to 95% relative compaction.

- 2. Finishing** -- Concrete shall not be placed or finished in the rain. It shall be the Contractor's responsibility to schedule construction operations accordingly.

All gutters shall be flow tested with water during the pour to assure proper drainage. Following concrete finishing, no water shall pond in the gutter pan.

All concrete surfaces shall be completed with a medium broom finish unless otherwise specified. A heavy broom finish is not allowed. A concrete finish not conforming to the Caltrans Standard Specifications with regard to blemishes and alignment tolerances shall be cause for rejection of the work.

No stamps advertising construction companies or other private concerns shall be placed in the concrete.

A detectable warning (truncated dome) panel shall be placed at the back of curb line, immediately behind the curb and gutter, centered in the opening to the street (regardless of slope) at every curb ramp (and shall not be placed on the sloped portion of the Case C ramp as shown on Caltrans Standard Plan RNSP A88A). The panel shall consist of a one piece, four foot by three foot panel or two, two by three foot panels. The four foot dimension of the panel shall be

along the face of curb. Two piece units shall be attached at the factory. The top, flat, dome panel surface (excluding the domes) shall be placed flush with the adjacent top of concrete surface.

Any runoff water standing behind the curb on the panel shall be cause for replacement of the panel. See Section 71-5 (Materials).

- 3. **Tool joints and score marks** -- Tool joints and score marks shall be placed through the sidewalk, curb and gutter section at the following intervals for the sidewalk widths indicated. All tool joints shall be a minimum two inches. There shall be no expansion joint material used in the City right of way.

The purpose of the tool joint is to separate the aggregate and control cracking. During concrete finishing, after placement of a minimum two inch deep tool joint, the joint shall be readdressed/finished with a 3/8 inch joint tool, per CST Detail ST-1.

Sidewalk Width (ft.)	Deep Tool Spacing (ft.)	Score Mark Spacing (ft.)
4	12	4
5	10	5
6	12	6
8	12	6
10	10	n/a

A score mark shall be placed at the back of the curb for the total length of all monolithic curb, gutter and sidewalk including through curb ramps and driveways. The above intervals for perpendicular score marks in sidewalk shall also apply through curb ramps and driveways.

All barrier curb and valley gutters shall include deep tool joints at 12 foot intervals maximum.

The use of sawcutting in lieu of deep tool joints is not acceptable.

- 4. **Grades** -- All sidewalks (including portions through driveways and curb ramps) shall be constructed with a minimum crossgrade of 1% and a maximum of 2% (with the exception of curb ramp landings, which shall be a minimum of 1.5% and a maximum of 2% grade to the street).

Parallel to the street, the grade of the curb ramp landing shall conform to the longitudinal grade of the street.

For all curb ramps, the minimum grade in the direction of travel is 7%, the maximum 8.33%.

For a Case C ramp on a street with a steeper longitudinal grade, (where the ramp on the higher side of the landing must be lengthened to achieve the maximum 8.33% grade), 25 feet shall be the maximum length transition required.

For the ramp to the lower side of the landing, (where the ramp must be shortened to achieve the minimum 7% grade), four feet shall be the minimum length transition allowed.

For meandering sidewalks, the maximum grade in the direction of travel shall be 4% if the street grade allows. If the longitudinal street grade exceeds 4%, the curb side of the meandering sidewalk shall parallel the grade of the back of curb, maintaining a grade of 2% from the edge of sidewalk to the back of curb. For all meandering sidewalks, a minimum crossgrade of 2% shall be maintained from the edge of sidewalk, across the planter to the back of curb.

Where curb ramp landings adjoin the back of curb, the top of curb shall be sloped up from the gutter flowline ½ inch in six inches (8%) to the back of curb for Type 2, vertical curb and gutter. For Type 1 roll curb and gutter, the top of curb shall be sloped up ¾ inch in 10 inches (7.3%). See CST ST-3 and ST-4.

Gutter slope from lip to flowline shall be 5% conforming to CST Detail ST-1.

The preceding slope specifications conform to ADA, California Division of the State Architect, and Caltrans Standard Specification requirements. Any finished concrete not conforming to these slope specifications shall be removed and replaced by and at the expense of the contractor.

5. **Monolithic sidewalk, curb and gutter** -- All adjoining sidewalk, curb and gutter shall be poured monolithically.
6. **Curb and gutter installation in an existing street** -- In an existing street, a minimum width of 24 inches of existing asphalt concrete paving shall be removed outside the proposed gutter lip and the lip poured against a form board. The resulting patch between the gutter lip and the existing pavement shall be six inches thick, or the thickness of the existing pavement, whichever is greater. The AC patch shall be placed within two weeks of the conclusion of the concrete pour.

The minimum waiting period for patching is three days or, the length of time needed for the concrete to reach 80% of it's required ultimate strength, whichever is more. The gutter may be poured against the existing pavement if the Public Works Inspector determines the pavement edge is flawless. In this case, the gutter lip shall not be edged and shall be poured 1/4 inch below the existing pavement.

7. **Curb Ramps, General** -- See CST Details ST-3, ST-4, ST-5, ST-6 and ST-18. Other ramp configurations in the Caltrans Standard Plans may be used upon the approval of the City Engineer only if site conditions prohibit use of Roseville's standard ramps.

All grade changes at the back of walk for curb ramps shall be staked by a licensed surveyor, conforming to these Construction Standards.

Specifications for curb ramps in the Construction Standards take precedence over the Caltrans Standard Plans and Specifications. Where there are discrepancies between details shown on the approved plan sheets and the Construction Standards, the plans shall be revised to conform to the Construction Standards unless specifically approved by the City Engineer.

8. **Epoxy Work** -- Epoxy shall be liberally applied to a minimum of 95% of one of the existing surfaces to be connected. Epoxy shall be two part and conform to Section 71-5 (Materials).
9. **No Sidewalk at Back of Retaining Curb** -- At any curb ramp, no pedestrian surface (i.e., concrete, asphalt concrete, paving stones, etc.) adjacent to the back of sidewalk, shall be constructed within 3 feet behind the retaining curb. This area shall be finished with landscaping, cobbles or other non-pedestrian surface only. If the occasion arises wherein the City Engineer determines it justified to place concrete behind the retaining curb, the top and face of the retaining curb shall be painted yellow.
10. **Curb, Gutter and Sidewalk Patching** -- Patch material shall conform to Section 71-5 (Materials). The patch shall be applied by a professional concrete mason. The patch shall be flush with the existing concrete and a similar finish shall be maintained. The Public Works Inspector shall determine if the damage to the concrete warrants patching. Generally, any conspicuous damage shall be patched.
11. **Doweling New Concrete to Existing** --When pouring combinations of sidewalk or curb and gutter contiguous to existing, the existing concrete vertical face shall be doweled three feet on center with 16 inch long, grade 60, #4 rebar penetrating four inches into the existing

curb, four inches below top of curb. The dowel hole shall be 5/8 inch diameter at a slight angle horizontally. The penetrating portion of the dowel and the entire cleaned, vertical surface of the adjoining, existing concrete shall be 95% coated with two part epoxy. All abutting sidewalk shall be doweled mid-section with two dowels for four through six foot wide sidewalk and three dowels for wider sidewalk. Abutting curb and gutter ends shall be doweled twice, 18 inches apart, centered on the curb and gutter section. See Section 71-5 (Materials) for epoxy.

Replaced sections shall be removed back to score marks, expansion joints or deep tool joints; or at the discretion of the Public Works Inspector.

If the existing edge is damaged during removal, the concrete shall be sawcut again at the Public Works Inspector's discretion.

12. Sidewalk, Curb and Gutter Replacement -- Where sidewalk and/or curb and gutter is being replaced, the maximum length of sidewalk that may be replaced non-monolithically (without the attached curb and gutter) is 20 feet. If more than 20 feet is damaged continuous, the total sidewalk, curb and gutter section shall be removed and replaced monolithically. Where sidewalk, curb and gutter or curb ramps and driveways with sidewalk, curb and gutter as portions thereof are replaced, all replacement shall conform to the latest Construction Standards.

13. Cobbled Median Islands -- Cobbles in median or pork chop islands shall be set in four inches of class A, six sack, pea gravel concrete. The top surface of the concrete shall be flush with the top of curb.

Cobbles shall be four to six inches in size, with 1/3 exposed above the top of curb, per Caltrans Specifications. Base for concrete may be native soil compacted to 95% or Class II, 3/4 inch aggregate base. On existing pavement, the two acceptable alternatives for base are 3/4 inch aggregate base or total depth concrete.

14. Damaged Gutter Lip -- Gutter lip damaged during the grading and rocking operation shall be patched or replaced per Section 71-4, C. 11. above. Any spall extending more than one inch into the gutter pan from the vertical face of the gutter lip shall be patched at a minimum.

15. Concrete and Asphalt Concrete Saw Cutting -- Residual from sawcutting shall be removed. The down stream drain inlet shall be protected. In no case shall the residual be allowed to enter the storm drain system. The above-specified cleanup shall be the responsibility of the contractor.

16. Concrete Cure -- All newly placed concrete shall be cured in accordance with the provisions in Section 90-7.01B of the State Standard Specifications and these Construction Standards. See Section 71-5.1. (Materials) of these Standards for curing compound. Exposed surfaces of all concrete sidewalk, curb and gutter, driveways, bus turnouts and curb ramps shall be coated with a pigmented curing compound immediately following surface finishing, prior to the moisture sheen disappearing from the surface. Curing compound shall be applied at a rate of one gallon per 150 square feet, or per the manufacturer's recommendations, whichever is greater, unless otherwise specified.

D. Asphalt Concrete Paving -- All asphalt concrete (AC) shall be installed per provisions in Section 39 of the Caltrans Standard Specifications, with exception to the number of roller passes required to achieve compaction, which shall be at the discretion of the contractor. The final product shall be a minimum acceptable relative compaction for the AC of 93%.

Compaction testing shall be accomplished immediately after AC finishing, and shall conform to CalTrans Test Method 375 or ASTM Method D2950.

No paving shall occur until all underground work is completed and subgrade and/or aggregate base or lime and flyash or cement treated base have been accepted by the Public Works Inspector.

Longitudinal joints in successive pavement lifts shall be off-set from lift to lift a minimum of one foot. The surface pass seam shall be located on the lane line.

Final, compacted pavement height shall be 1/4 inch above the gutter lip, except for six feet at the curb ramp opening, where it shall be flush with the top surface of the gutter lip.

Existing AC surfaces to remain shall be cut in a straight line parallel to the street centerline, and the exposed edge shall be tacked with SS1H emulsion or equivalent prior to paving. The exposed base material shall be graded and recompacted per these Construction Standards prior to paving.

The horizontal surface of AC paved against an existing AC surface shall be flush with the existing surface.

If extruded concrete curb is removed for pavement widening, the asphalt concrete pavement shall be patched with asphalt concrete fines (Topeka) to the satisfaction of the Public Works Inspector.

Prior to City acceptance of the improvements (Certificate of Completion), streets shall be flooded to check for standing water. This procedure shall be repeated prior to the expiration of the warranty period. This may be accomplished with a water truck or with rain water. All low areas in the asphalt concrete pavement holding 1/16 inch or more of water shall be marked by the Public Works Inspector and patched by the contractor to the inspector's satisfaction with asphalt concrete fines (Topeka).

Prior to permanent patching in a pavement removal area, fresh cut-back (temporary pavement) in a minimum thickness of two inches shall be placed as a driving surface.

Where an excavation in the public right of way is backfilled with two sack cement slurry per these Construction Standards, the slurry may be brought to the top of the trench until permanent patching. Whether the surface material is cut-back or slurry, the Contractor shall be tenacious in maintaining the surface in a condition and to a grade comparable to the permanent patch. No other materials are allowed as temporary pavement. Placement of steel plates over fresh slurry may be employed per Section 21-2, I. 5. of these Standards.

The temporary surface shall be flush with the surrounding pavement and shall accommodate a smooth drive across it.

Sand and dirt shall not be allowed to accumulate on the slurry surface and adjacent street. It shall be swept daily if necessary.

A fog seal or slurry seal may be required at the Public Works Inspector's discretion following asphalt concrete paving if it is determined the paving surface is sufficiently irregular or boney to warrant it.

Utility boxes in asphalt concrete, off-street paths shall include a 12 inch x 12 inch, concrete collar (Class A, six sack). The top of the collar shall be two inches below the surrounding pavement and the area shall be patch-paved with asphalt concrete as with manholes, water valves and monuments in the streetway.

Where crack sealing is required: Cracks less than 1/4 inch in width shall be sealed with SS1-H oil emulsion and 30 grit sand. Cracks from 1/4 inch to 3/4 inch shall be sealed with CRAFCO hot melt rubber sealant or approved equal. Excess sealant shall not extend more than one inch outside the crack onto the pavement surface or above the finished surface of the street. Where cracks larger than 3/4 inch (or pavement alligating) occurs, asphaltic concrete patching may be required at the discretion of the Public Works Inspector.

Testing -- The City Engineer shall have the right to:

1. Obtain samples of all materials to be used in the work and to require testing of such samples for the purpose of determining specifications compliance.
2. Obtain said samples at the point of delivery and/or at the point of manufacture.
3. Inspect sources of materials to be used in the work to determine workmanlike procedures used by the materials supplier.

Any material testing completed or not completed by the City Engineer does not relieve the Contractor of complying to the provisions herein.

Finished asphalt concrete pavements shall conform to the following specified compaction requirements:

<u>In Place Compaction</u>	<u>Status</u>
93% or greater	acceptable compaction
91 - 92.9%	Reclamite Rejuvenator Seal (or approved equal)
89 - 90.9%	Slurry Seal, Caltrans Type II
88.9% or less	Remove and replace

- E. Sound and Retaining Walls** -- Construction of sound and retaining walls shall conform to the approved plans. The Public Works Inspector shall inspect all sound and retaining walls shown on the approved subdivision grading or improvement plans. An anti-graffiti coating per Section 71-5 (Materials) and per the manufacturer's recommendations shall be applied to the City side of all sound and retaining walls bounding the City right-of-way.

The Public Works Inspector shall be furnished a letter from the applying contractor certifying that the coating has been applied per the Manufacturer's recommendations, prior to the Certificate of Completion.

The top course of loose block retaining wall such as "Keystone" type shall be epoxied on. The adhesive shall conform to Section 71-5 (Materials) below.

- F. Survey Monuments** -- All survey monuments shall be installed per Construction Standard Detail ST-15. Surface monuments shall be driven flush with the surface of pavement.

Survey monument caps shall be peened and stamped and rebar shall be set at the back of lot prior to the Certificate of Completion.

All rear lot property corners shall be marked with a 1/2 inch rebar, 12 inches long, the top flush with finish grade. All lot corners at the street shall be marked with a pneumatically set concrete nail and surveyor's tag, six inches into the back of sidewalk or a sawcut score mark, a minimum of 4 inches long and 1/4 inch deep, at the back of the City sidewalk or back of curb, whichever applies, or as indicated on the recorded parcel or final map.

- G. Street Barricades** -- All street and sidewalk barricades shall conform to Construction Standard Details ST-13 and ST-14, respectively. Sidewalk barricades are required at the termination of all new sidewalk improvements.
- H. Pavement Removal** -- Upon demolition of concrete and asphalt concrete pavement, rubble shall be immediately removed or hauled from, and not piled in the City right-of-way.
Disposal of such materials shall conform to all local ordinances and regulations of the City of Roseville and the County of Placer relating to land grading, flood plains, drainage facilities and disposal of surplus materials.
- I. Utility Boxes** -- Boxes for dry utilities shall not be placed in asphalt concrete pavement, the gutter pan, in driveways or in the lower half of the ramped portion of curb ramps. Utility boxes may be placed in City sidewalk only upon the approval of the Public Works Inspector.

71-5 MATERIALS --

- A. Aggregate Base and Subbase** -- All aggregate base and subbase (AB and ASB) materials shall be Class 2 as specified on the approved improvement plans and shall conform to provisions in Sections 25 and 26 of the Caltrans Standard Specifications.

Asphalt concrete grindings may be used as AB or ASB provided the Contractor supplies the City documentation that the material meets the Class 2 specifications, and there are no environmental issues.

- B. Concrete** -- All concrete curbs, curbs and gutters, sidewalks, curb ramps and driveways (except otherwise noted on the approved plans) shall be Class A, six sack, Type II mix and shall conform to provisions in Section 90 of the Caltrans Specifications.
- C. Asphalt Concrete** -- The following provisions for Asphalt Concrete material shall apply to work completed within these specifications.

Asphalt concrete shall comply with the provisions of Section 39 of the California State Standard Specifications and as modified herewith. The requirements provided within these special provisions shall supersede State Specifications where conflicts or other disparities exist.

Asphalt concrete shall be hot plant mixed and shall be furnished from the plant at a temperature not to exceed 325 degrees F.

Asphalt concrete for paving work shall be Type A, 1/2 inch Maximum Medium Gradation, conforming to the requirements of Section 39-2 of the State Standard Specifications.

Asphalt binder shall be an AR-8000 viscosity graded, steam refined paving asphalt conforming to Section 92 of the State Standard Specifications.

All types of Asphalt Concrete shall comply with the specifications below:

The actual asphalt cement content may vary up to 0.5% plus/minus from the target optimum bitumen content (OBC) unless the job-mix-design and final product indicate the required provisions are not met.

NOTE: At the OBC, the compacted mixture shall have a minimum Hveem stability of 37 for Type A asphalt concrete.

The suggested job-mix-design air voids of 3% to 5% are provided to help obtain compaction requirements in the field and are not a specification requirement.

Only materials conforming to the specifications shall be incorporated in the work. The materials shall be manufactured, handled and used to industry standards.

Submittals: Each material supplier providing asphalt concrete for improvement projects within the City shall submit a design mix and certificate of compliance to the Construction Management Section of the Public Works Department each January 1. The Certificate of Compliance shall be signed by the material supplier or his representative. Design mix changes shall not occur without the written approval of the City engineer.

The mix design shall indicate all of the following:

1. Percentage passing each sieve size
2. Percent asphalt recommended
3. Percent voids*

4. Stability*

5. Maximum theoretical unit weight*

*The items with asterisks shall be provided at each asphalt content used to arrive at the recommended optimum bitumen content.

The Contractor shall be responsible for all costs associated with the required job-mix-design.

- D. Lime/Fly Ash or Cement Treated Subbase** -- On a case by case basis, lime/fly ash or cement treated subbase may be an acceptable substitute for placement of compacted aggregate base material. Prior to plan approval, the Developer shall submit to the City Engineer for review and approval, a proposal for lime/fly ash or cement treatment sections and compaction procedures, accompanied by recommendations from a California licensed, geotechnical engineer.
- E. Truncated Domes** -- Truncated dome panels shall be of vitrified polymer composite construction, embedded type, manufactured by Armor Tile Tactile Systems, Buffalo, New York, or approved equal. The dimensions and interval of the truncated domes within the panel shall conform to Caltrans Standard Plan RNSP A88 and Division of the State Architect Accessibility Reference Manual, Figure No. 31-23A. The orientation of the dome pattern for all panels shall be parallel with the panel edges, not diagonal as shown in the preceding referenced details.
- F. Graffiti Coating** -- Block Guard (Prosoco), Monochem Perma Shield (Vista Paint), Acryli-Master (Graffiti Master), GCP 1000 (Genesis Coatings Inc.) or approved equal, non-sacrificial type only.
- G. Epoxies, Patching Material** -- Following are products specified for the indicated applications.
1. **Bonding extruded curb to asphalt concrete pavement; bonding concrete to existing during pour; bonding the top course of loose block, sound/retaining wall:** Burk Epoxy Binder 2104 (Supplier: Whitecap), DFC Resi-Weld, ER-43, Type 2 (Supplier: Spec-West) or approved equal.
 2. **Anchor Bolts:** Seal Tight Resi-Weld Gel Paste Unitized Cartridge Epoxy (Supplier: Spec West), Covert Operations CIA Gel 7000 (Supplier: White Cap) or approved equal.
 3. **Patching:** Target Speed Set (Supplier: Spec-West), Burke Fast Patch 928 (Supplier: White Cap) or approved equal.

- H. **Reinforcement Bar** -- Rebar shall be grade 60 steel, deformed type. Smooth bar shall not be allowed. All rebar shall be number four (4) unless otherwise specified on the plans.

- I. **Concrete Curing Compound** -- Curing compound shall conform to ASTM C-309, Type 1-D, Class B, resin base, clear with fugitive red dye. Approved products include Burke Aqua Resin Cure (with dye), W.R. Meadows 1100-Clear Series (with dye) or approved equal.

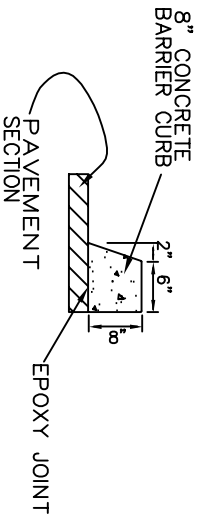

TYPE 1 BARRIER CURB
(ADJACENT TO UNIRRIGATED AREAS)

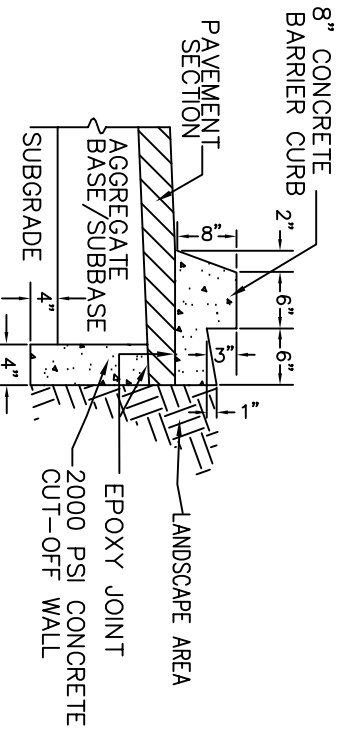

NOTE: CUTOFF WALL MAY EXTEND UP TO PAVEMENT SURFACE OR AS SHOWN ABOVE.

TYPE 2 BARRIER CURB
(ADJACENT TO IRRIGATED AREAS)

- NOTES:
1. ALL CONCRETE SHALL BE CLASS A, SIX SACK UNLESS OTHERWISE NOTED
 2. SEE DETAIL CST ST-1 FOR TOOL JOINTS.

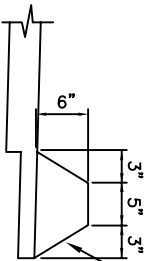

BACK UP WITH SOIL OR AGGREGATE PER THE PLANS.

STATE TYPE A HIGH DIKE
(ASPHALT CONCRETE DIKE)

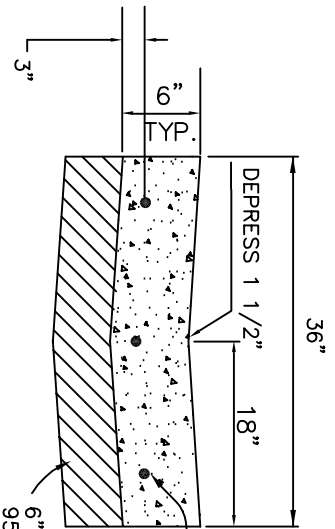

#5 REBAR GRADE 60 CONTINUOUS. USE 3" DOBIES (REBAR SPACERS) WITH WIRE TIES AT 3" CENTERS.

36 INCH VALLEY GUTTER
(ALLEYS ONLY)

Larry D. Pagel
LARRY D. PAGEL
DIRECTOR OF PUBLIC WORKS/CITY ENGINEER



DEPARTMENT OF
PUBLIC WORKS

**BARRIER CURBS
AND VALLEY GUTTER**

SCALE: NONE
REVISED: MAY 16, 2001
DRAWN BY: STAFF
APPROVED BY: LARRY D. PAGEL

CST
ST-2

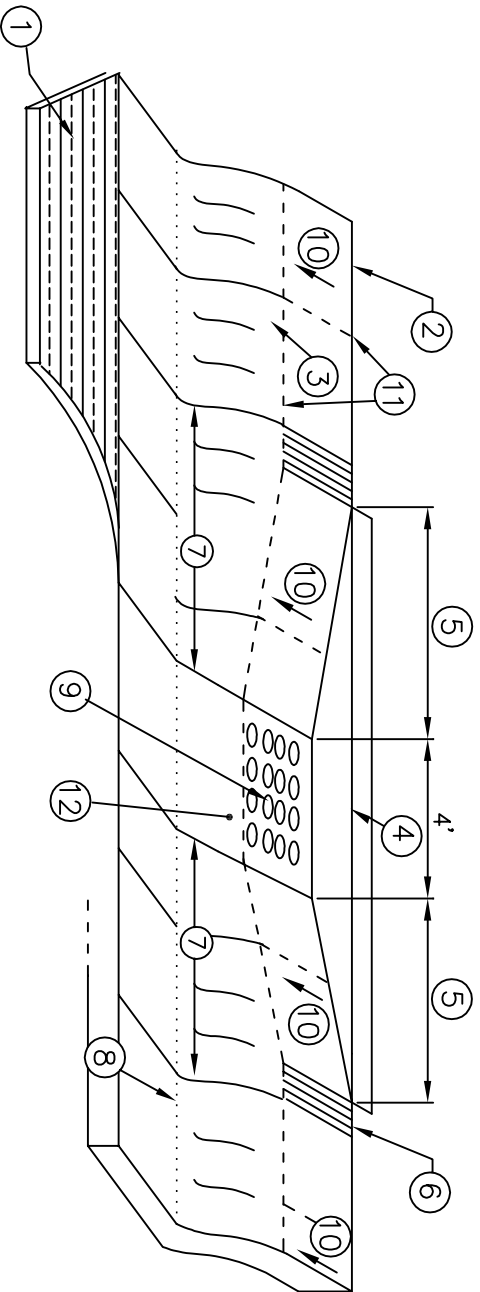

LEGEND

1. STREET PAVEMENT
2. STANDARD SIDEWALK WIDTH IS 4' UNLESS SHOWN OTHERWISE ON PLANS.
3. TOP FACE OF CURB IS 3-5/8" HIGH (FROM FLOWLINE).
4. 6" WIDE RETAINING CURB, HEIGHT TO BE DETERMINED BY PROJECTED BACK OF WALK GRADE. POUR MONOLITHIC WITH SIDEWALK; MINIMUM DEPTH SECTION FLUSH WITH BOTTOM OF SIDEWALK.
5. THE MINIMUM GRADE IN THE DIRECTION OF TRAVEL IS 7%. THE MAXIMUM 8.33% FOR CASE C RAMPS. ON STEEPER GRADES WHERE 8.33% CANNOT BE ACHIEVED, 25 FEET IS THE MAXIMUM LENGTH TRANSITION REQUIRED.
6. GROOVES PER STATE STANDARD, TYP.
7. TOOL JOINT, SEE DETAIL CST ST-1.
8. GUTTER PAN, FLOW LINE
9. TRUNCATED DOMES: SEE SECTION 71-4 C.2. AND 71-5 OF THE CONSTRUCTION STANDARDS FOR REQUIRED PRODUCT OR APPROVED EQUAL INFORMATION. 1 1/2 - 2% GRADE TO STREET.
10. CROSS-GRADE SHALL BE 1% MIN, 2% MAX. (LANDING 1 1/2% MIN. TO STREET) SCORE MARK TYPICAL
11. ACROSS THE FOUR FOOT WIDTH OF THE CURB RAMP OPENING, THE TOP OF CURB SHALL BE SLOPED UP FROM THE FLOWLINE TO THE BACK OF CURB 3/4 INCH.

NOTES:

- A. SIDEWALK THICKNESS IS 6 INCHES. CONCRETE SHALL BE CLASS A, 6 SACK.
- B. SEE SECTION 71-4 C.6. OF THESE STANDARDS FOR ASPHALT CONCRETE PATCH ADJACENT TO GUTTER LIP.

 LARRY D. PAGEL
 DIRECTOR OF PUBLIC WORKS/CITY ENGINEER



DEPARTMENT OF
PUBLIC WORKS

RESIDENTIAL CURB RAMP
CASE C

SCALE: NONE
 REVISED: MAY 16, 2001
 DRAWN BY: STAFF
 APPROVED BY: LARRY D. PAGEL

CST
ST-3

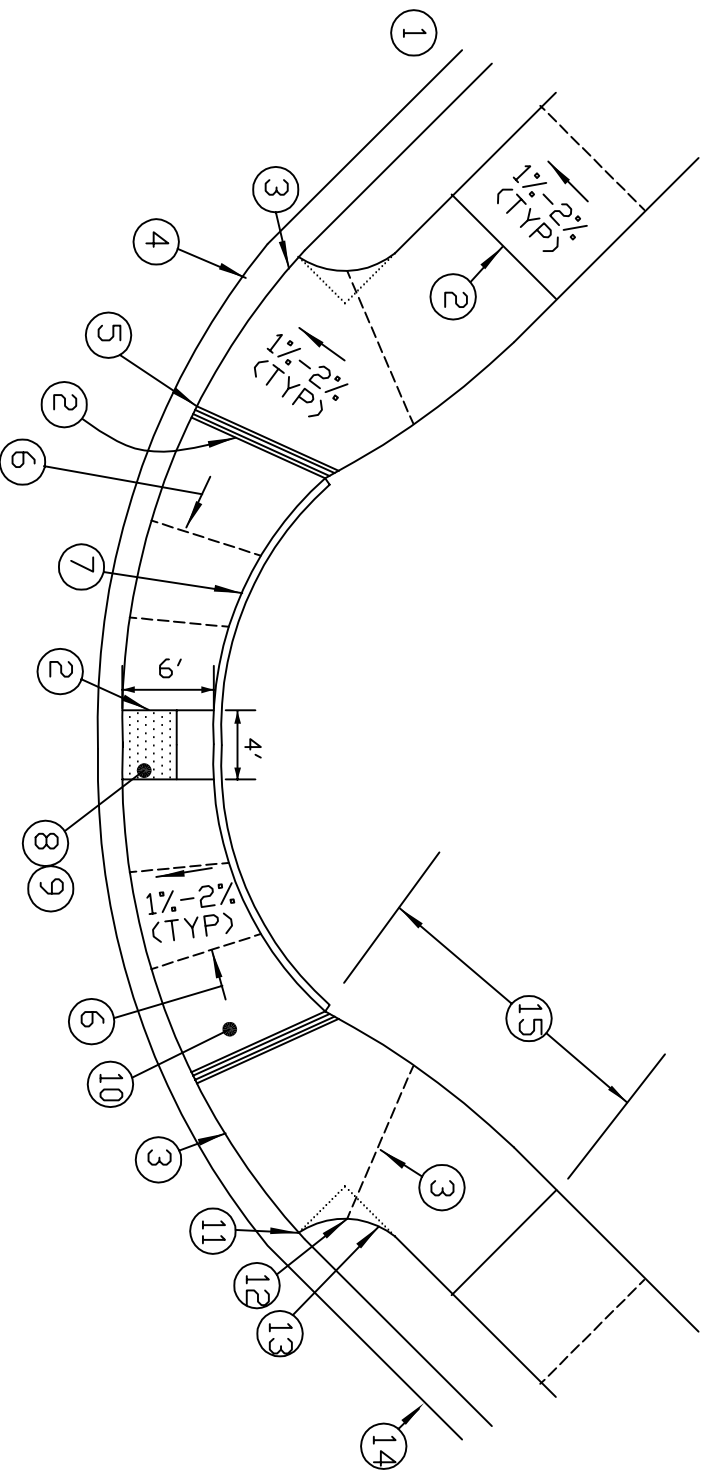

NOTES:

1. STREET PAVEMENT
2. TOOL JOINT, SEE DETAIL CST ST-1.
3. SCORE MARK (BACK OF CURB, TYP)
4. TYPE 2 GUTTER
5. GROOVES PER CALTRANS STANDARD PLAN A88A (TYP)
6. THE MINIMUM GRADE IN THE DIRECTION OF TRAVEL IS 7%, THE MAXIMUM IS 8.33%. FOR CASE C RAMPS, ON STEEPER GRADES WHERE 8.33% CANNOT BE ACHIEVED, 25 FEET IS THE MAXIMUM LENGTH TRANSITION REQUIRED.
7. SIX INCH WIDE RETAINING CURB, MONOLITHIC WITH SIDEWALK; PROJECTED BACK OF WALK GRADE SHALL DETERMINE ELEVATION.
8. DETECTABLE WARNING PANEL, TRUNCATED DOME, SEE SECTIONS 71-4, C-2, AND 71-5 OF THESE STANDARDS. 1 1/2 - 2% GRADE TO STREET.
9. SLOPE TOP OF CURB DOWN TO FLOWLINE 1/2 INCH FOR TYP 2 CURB AND GUTTER AT RAMP OPENING; NO LIP. SEE SECTION 71-4 C.4.
10. TRANSITION FROM SIX FOOT DEEP OPENING TO MEANDERING WALK WIDTH.
11. TERMINATE PLANTER RADIUS AT CURB RETURN. RADIUS SHALL MATCH PLANTER WIDTH.
12. RADIUS OR SQUARE AS SHOWN ON PLANS. PLANTER WIDTH VARIES.
13. ALL SIDEWALK SHALL BE SIX INCHES THICK.
14. SEE SECTION 71-4 C.6. FOR AC PATCH ADJACENT TO GUTTER LIP..
15. REVERSE CURVE TRANSITION FROM TOP OF RAMP TO BACK OF MEANDERING SIDEWALK.

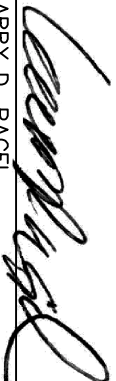
 LARRY D. PAGEL
 DIRECTOR OF PUBLIC WORKS/CITY ENGINEER



DEPARTMENT OF
PUBLIC WORKS

RESIDENTIAL CURB RAMP
CASE C
(DETACHED SIDEWALK)

SCALE: NONE
 REVISED: MAY 16, 2001
 DRAWN BY: STAFF
 APPROVED BY:

CST
ST-4

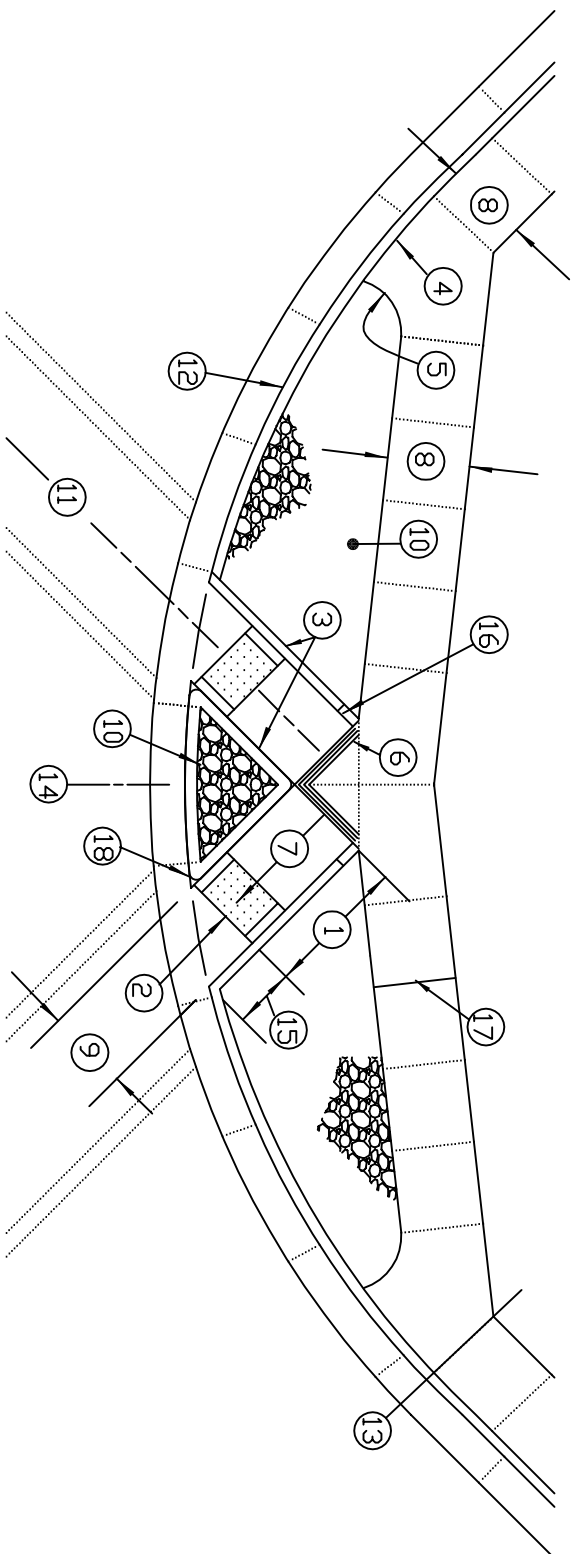

NOTES:

1. RAMP LENGTH SHALL BE NINE FEETON THE INSIDE OF THE RAMPS. RAMP RISE SHALL BE 0.7 FEET (8 3/8 INCHES). THIS SHALL APPLY TO THE RAMP WHICH ADJOINS THE CITY GUTTER AT THE LOWEST ELEVATION. THE GRADE OF THE OPPOSITE RAMP SHALL BE DICTATED BY THE ADJOINING TOP OF THE LOWER RAMP. THE CROSS GRADE (1% TO 2%) OF BOTH RAMPS SHALL BE SLOPED THE SAME DIRECTION AS THE GUTTER FLOWLINE. CENTERLINE OF THE RAMP SHALL BE THE SAME AS THE CENTER LINE OF THE CROSSWALK.
2. DETECTABLE WARNING (TRUNCATED DOME PANEL) PER SECTION 71-5 (MATERIAL) OF THESE CONSTRUCTION STANDARDS. (TYPICAL)
3. CONCRETE RETAINING CURB, SIX INCHES WIDE x SIX INCHES HIGH.
4. TYPE 2 CURB AND GUTTER, MONOLITHICALLY WITH SIDEWALK AND RAMPS.
5. THREE FOOT MINIMUM RADIUS; TANGENT IS PERPENDICULAR TO THE BACK OF CURB.
6. 12 INCH WIDE GROOVE PATTERN PER CALTRANS STANDARD PLANS, DETAIL A88A.
7. 7% MINIMUM, 8.33% MAXIMUM
8. SIDEWALK WIDTH PER PLANS, 5 FEET MINIMUM, SIX INCHES THICK. ALL CONCRETE SHALL BE SIX SACK, CLASS A.
9. FIVE FEET (WITH FOUR FOOT PANEL CENTERED).
10. COBBLES PER SECTION 71-4 C. 13. OF THESE CONSTRUCTION STANDARDS.
11. CROSSWALK (CENTERLINE SAME AS RAMP CENTERLINE)
12. 26 FOOT TO 62 FOOT RADIUS PER PLANS.
13. CURB RETURN, ANGLE POINT IN BACK OF SIDEWALK.
14. CENTERLINE OF CURB RETURN/RADIUS.
15. TRANSITION FROM 1% TO 2% CROSS GRADE TO GUTTER FLOWLINE GRADE.
16. RETAINING CURB (NOTES.) SHALL TRANSITION FROM SIX INCHES HIGH TO ZERO IN TWO FEET WHERE IT MEETS THE SIDEWALK.
17. SEE DETAIL CST ST-1 FOR TOOL JOINTS.
18. SIX INCH RADIUS (TYP.)

 LARRY D. PAGEL
 DIRECTOR OF PUBLIC WORKS/CITY ENGINEER

 DEPARTMENT OF PUBLIC WORKS
CASE E CURB RAMPS
COLLECTOR/INDUSTRIAL/ARTERIAL
STREETS

SCALE: NONE
 REVISED: MAY 16, 2001
 DRAWN BY: STAFF
 APPROVED BY: LARRY D. PAGEL
CST
ST-5

NOTE: ALL CONCRETE SHALL BE CLASS A, SIX SACK.

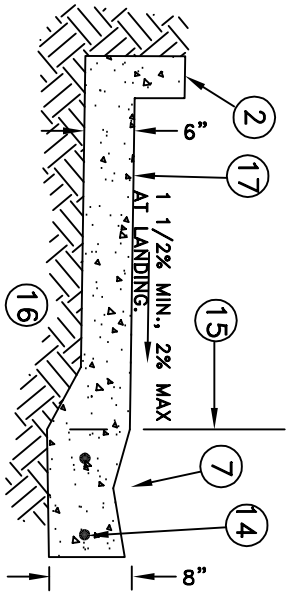
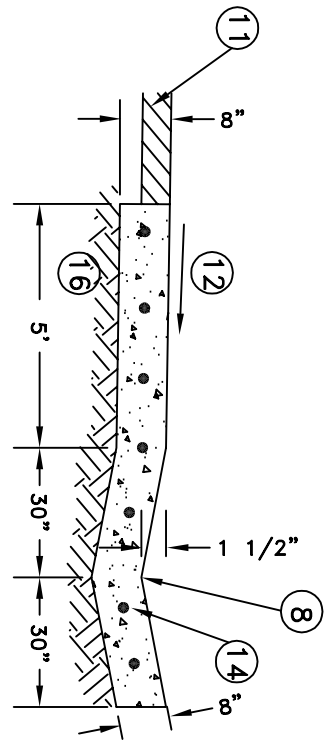
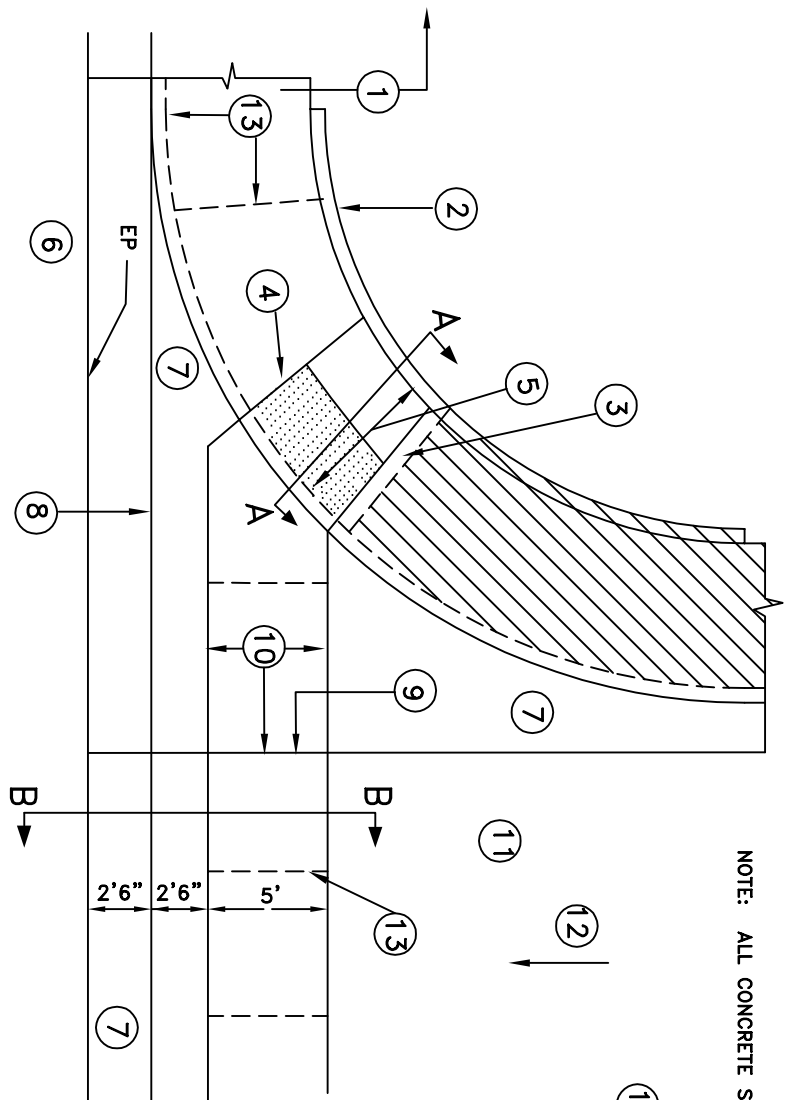

LEGEND

1. TYPE 2 CURB AND GUTTER WITH SIDEWALK OUTSIDE DRIVEWAY AREA
2. RETAINING CURB AT BACK OF WALK, HEIGHT VARIES
3. PLACE RAMP IF SIDEWALK EXTENDS ON SITE (CROSS-HATCHED AREA); EXTEND RETAINING CURB IF NO ON-SITE SIDEWALK. (AT #3 ARROW.)
4. CASE C RAMP WITH TRUNCATED DOME PANEL; NUMBER 4 LINE COINCIDES WITH BACK OF V GUTTER (TYP). SLOPE TOP OF CURB 1/2 INCH AT OPENING, NO LIP. SEE SECTION 71-4 C.4.
5. LANDING DEPTH IS SIX FEET DEEP. TRANSITION TO ADJACENT WALK WIDTH FROM LANDING TO CURB RETURN.
6. STREET PAVING
7. DRIVEWAY 8 INCHES THICK PER SECTION B-B, SIDEWALK 6 INCHES PER SECTION A-A
8. GUTTER FLOWLINE
9. POUR GUTTER, WALKS AND CURBS MONOLITHICALLY. POUR MAY BE SEPARATED WITH COLD JOINT AT NUMBER 9 LINE.
10. TOOL JOINT, SEE DETAIL, CST ST-1.
11. PRIVATE PAVING PER APPROVED PLANS
12. MAXIMUM GRADE OF 2%, MINIMUM 1% TO 15 FEET BACK OF V GUTTER.
13. SCORE MARKS, TYPICAL, 1/8 INCH DEEP.
14. NO. 4 REBAR, 18 INCHES O.C. EACH WAY, THREE INCH DOBIES WITH WIRE TIES AT THREE FOOT INTERVALS, EACH WAY.
15. EXTENDED CURB FACE
16. IN DRIVEWAY, CLASS B, 3/4 INCH AGGREGATE BASE OR NATIVE SUBGRADE; EITHER PROCESSED TO 95% RELATIVE COMPACTION, UNDER SIDEWALK, NATIVE SOIL, MINIMUM 6" PROCESSED TO 95% RELATIVE COMPACTION. AGGREGATE BASE THICKNESS SHALL BE AT THE CONTRACTOR'S DISCRETION.
17. ALL SIDEWALK 1% MINIMUM, 2% MAXIMUM GROSS GRADE TOWARD STREET.



LARRY D. PAGEL
CITY ENGINEER/DIRECTOR OF PUBLIC WORKS

Larry D. Pagel

DEPARTMENT OF
PUBLIC WORKS

TYPE A-7
COMMERCIAL DRIVEWAY

SCALE: NONE
REVISED: MAY 16, 2001
DRAWN BY: STAFF
APPROVED BY: LARRY D. PAGEL

CST
ST-6

- NOTE:**
- A. DETAIL REFERENCES
CALTRANS TRAFFIC
MANUAL DETAILS
 - B. SEE CST ST-6
FOR A-7 DRIVEWAY DETAILS.

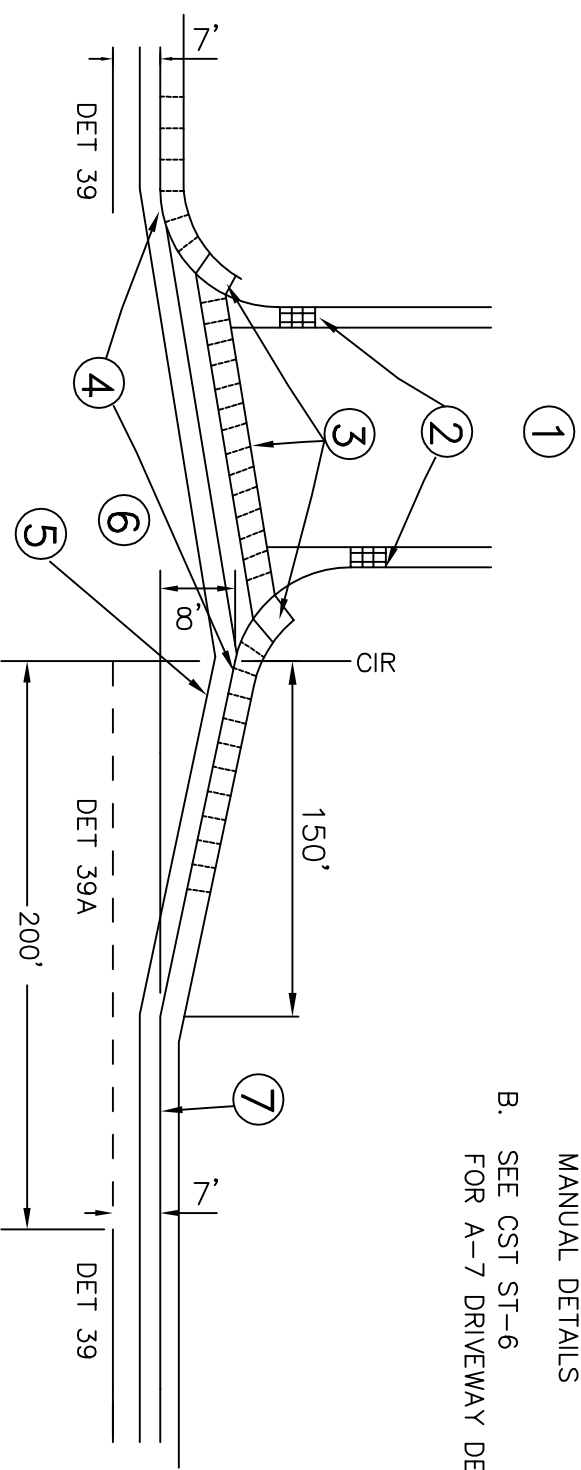

LEGEND

1. ON-SITE PAVEMENT
2. IF GUTTER DRAINS TOWARD SITE, CONSTRUCT CATCH BASIN AS REQUIRED PER APPROVED PLANS.
3. CURB RAMPS AND SIDEWALK
4. CENTERLINE OF VALLEY GUTTER SHALL INTERSECT CURB FACE AT OUTSIDE END OF EACH CURB RETURN
5. RIGHT TURN FLARE WITH STANDARD TYPE 2 CURB AND GUTTER
6. ASPHALT CONCRETE PAVEMENT SECTION PER PLANS
7. CURB FACE

Larry D. Pagel
 LARRY D. PAGEL
 DIRECTOR OF PUBLIC WORKS / CITY ENGINEER

CITY OF ROSEVILLE
 TRADITION. FIDES. PROGRESS.
 DEPARTMENT OF PUBLIC WORKS

RIGHT TURN CURB FLARE FOR A-7 DRIVEWAY OR PAVED ENTRY

SCALE: NONE
 REVISED: MAY 16, 2001
 DRAWN BY: STAFF
 APPROVED BY: PAGEL

CST ST-7

LEGEND

1. THE MAX. GRADE IS 5% IF LONGITUDINAL STREET GRADE ALLOWS. THE MAX. TRANSITION TO OBTAIN 5% IS 15 FEET. OTHERWISE, A MAX. GRADE OF 8.33% SHALL BE OBTAINED BETWEEN 15 AND 25 FEET. 25 FEET IS THE MAX. TRANSITION REQUIRED/ALLOWED, REGARDLESS OF LONGITUDINAL STREET GRADE.
2. TOOL JOINT, SEE DETAIL CST ST-1.
3. SCORE MARKS EVERY FOUR FEET FOR FOUR FOOT SIDEWALK AND 5 FEET FOR FIVE FOOT SIDEWALK ETC.
4. ONE INCH HIGH LIP AT 45 DEGREE BATTER.
5. TYPE 2 CURB AND GUTTER
6. DRIVEWAY WIDTH PER THE APPROVED PLAN.
7. ADJACENT SIDEWALK.

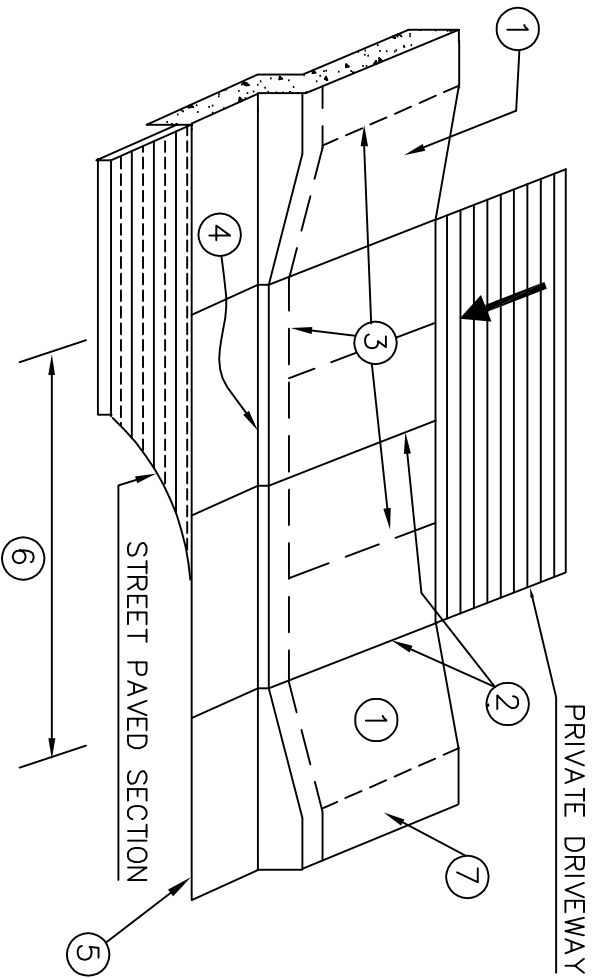

NOTES

- A. SIDEWALK CROSSGRADE THROUGH THE ENTIRE DRIVEWAY SHALL BE 1% MINIMUM, 2% MAXIMUM.
- B. CONCRETE SHALL BE EIGHT INCHES THICK WITH NO. 4, GRADE 60 REBAR AT 18 INCH CENTERS EACH WAY. USE THREE INCH DOBIES (REBAR SPACERS) AT THREE FOOT INTERVALS. EIGHT INCH SECTION IS FROM BOTTOM OF TRANSITION TO BOTTOM OF TRANSITION AND FROM GUTTER LIP TO BACK OF WALK. CONCRETE SHALL BE CLASS A, SIX SACK.
- C. BASE FOR CONCRETE SHALL BE NATIVE SOIL OR CLASS 2, 3/4 INCH AGGREGATE BASE, EITHER PROCESSED SIX INCHES THICK TO 95% RELATIVE COMPACTION. AGGREGATE BASE IS NOT ALLOWED UNDER SIDEWALK OUTSIDE DRIVEWAY.
- D. SEE SECTION 71-4 C.6. OF THESE STANDARDS FOR AC PATCH ADJACENT TO GUTTER LIP.
- E. FROM EIGHT TO TWENTY FEET BACK OF SIDEWALK, RAISE PRIVATE PAVING/LANDSCAPING TO A MINIMUM HEIGHT OF THE HIGHEST TOP OF CURB ELEVATION AT THE DRIVEWAY.

Larry D. Pagel
LARRY D. PAGEL
DIRECTOR OF PUBLIC WORKS/CITY ENGINEER



DEPARTMENT OF
PUBLIC WORKS

TYPE S
COMMERCIAL DRIVEWAY

SCALE: NONE
REVISED: MAY 16, 2001
DRAWN BY: STAFF
APPROVED BY: LARRY D. PAGEL

CST
ST-8

NOTES:

1. FOR COMMERCIAL DRIVEWAY: SIDEWALK, APRON AND GUTTER PAN SHALL BE EIGHT INCHES THICK WITH NO. 4 GRADE 60 REBAR ON 18 INCH CENTERS EACH WAY. USE THREE INCH DOBIES (REBAR SPACERS) AT THREE FOOT INTERVALS. FOR RESIDENTIAL: WALK, APRON AND GUTTER PAN SHALL BE SIX INCHES THICK, NONREINFORCED. FOR COMMERCIAL AND RESIDENTIAL, SIDEWALK, APRON AND GUTTER PAN SHALL BE PLACED MONOLITHICALLY. ALL CONCRETE SHALL BE CLASS A, SIX SACK.
2. STRAIGHT GRADE FROM SIDEWALK TO LIP AT FLOWLINE
3. ADJACENT SIDEWALK: IF EXISTING SIDEWALK EXCEEDS 2% CROSS GRADE, REPLACE FIVE FEET ADDITIONAL EXISTING AND TRANSITION TO ACCOMMODATE 2% MAXIMUM CROSS GRADE IN SIDEWALK WITHIN DRIVEWAY.
4. TYPE 2 CURB AND GUTTER: IF EXISTING IS NOT TYPE 2 SECTION, MATCH THE EXISTING GUTTER PAN UNLESS OTHERWISE REQUIRED PER THE APPROVED PLAN.
5. ONE INCH HIGH LIP AT 45 DEGREE BATTER.
6. DRIVEWAY WIDTH PER THE APPROVED PLAN.
7. SEE SECTION 71-4 C.6. OF THESE STANDARDS FOR AC PATCH ADJACENT TO GUTTER LIP.
8. TOOL JOINT, SEE DETAIL CST ST-1.
9. SCORE MARKS EVERY FOUR FEET FOR FOUR FOOT SIDEWALK AND FIVE FEET FOR FIVE FOOT SIDEWALK ETC.
10. SUBGRADE BASE FOR CONCRETE WITHIN CITY RIGHT-OF-WAY SHALL BE SIX INCHES OF NATIVE SOIL, OR CLASS II, 3/4 INCH AGGREGATE BASE, BOTH AT 95% RELATIVE COMPACTION.

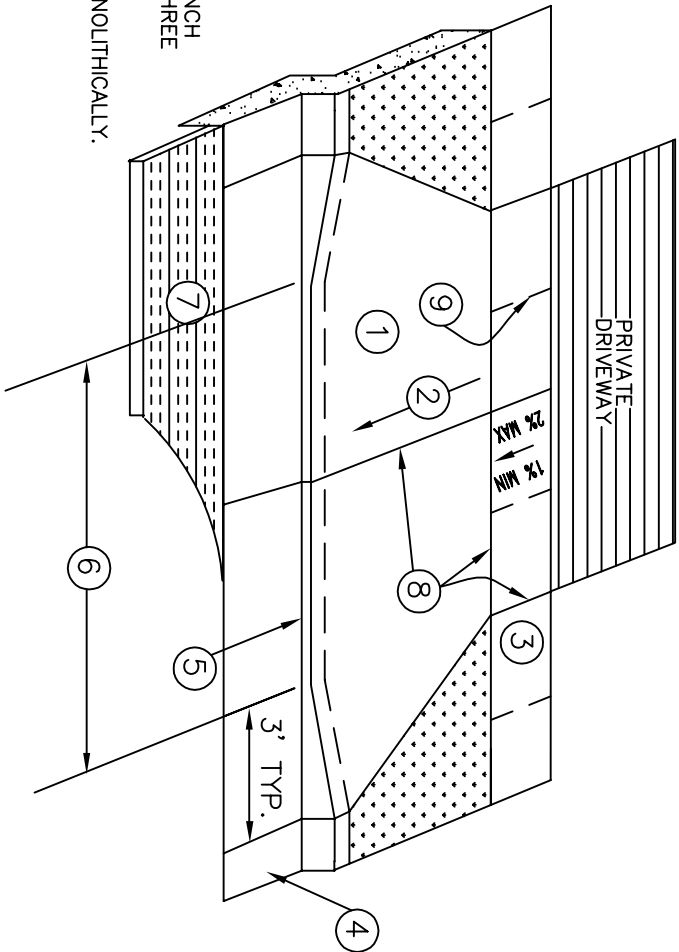

LARRY D. PAGEL
DIRECTOR OF PUBLIC WORKS/CITY ENGINEER



DEPARTMENT OF
PUBLIC WORKS

**RESIDENTIAL/COMMERCIAL
DRIVEWAY, TYPE D**

SCALE: NONE
REVISED: MAY 16, 2001
DRAWN BY: STAFF
APPROVED BY: LARRY D. PAGEL

CST
ST-9

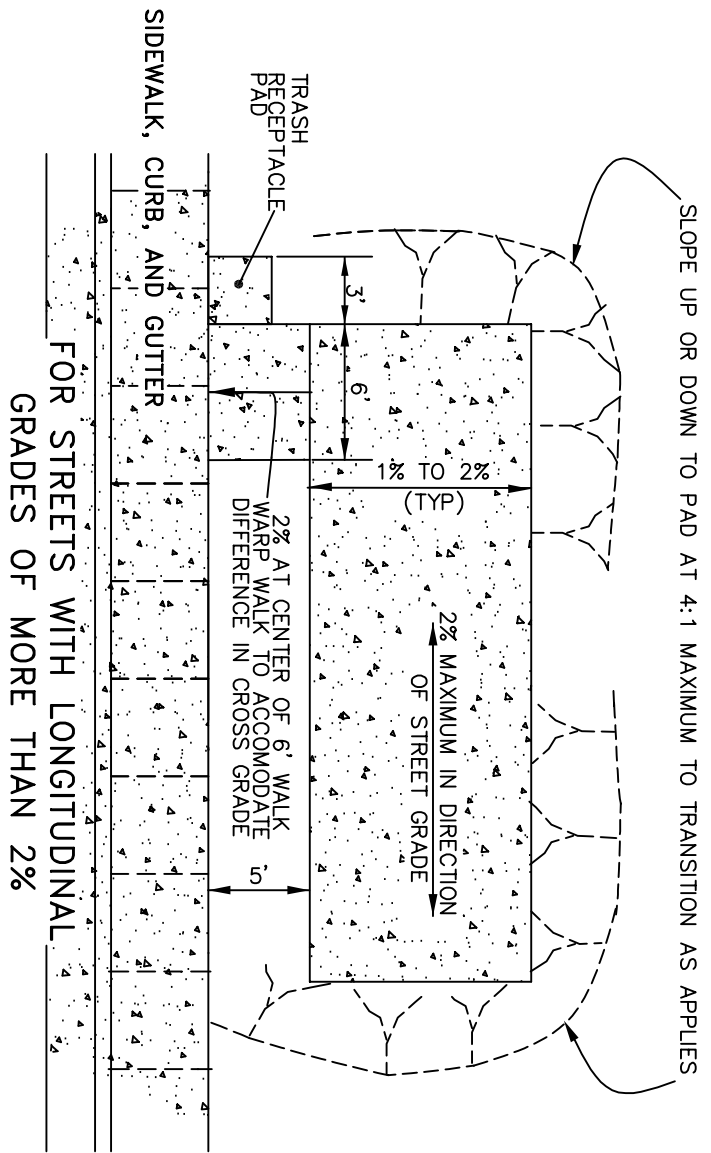
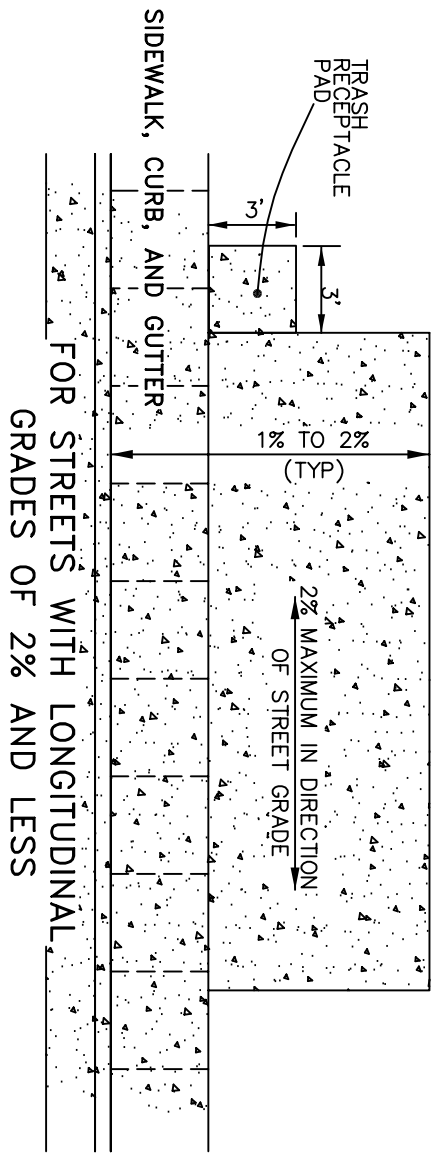

NOTES:

1. PADS SHALL BE SIX INCHES THICK, CLASS A, SIX SACK CONCRETE. SIX INCHES OF SUBGRADE SHALL BE PROCESSED TO 95% RELATIVE COMPACTION.
2. PAD SIZE: 7'x14' OR PER PLANS
3. FOR APPROVED BUS SHELTER STRUCTURES, SEE "CITY OF ROSEVILLE BUS SHELTER REQUIREMENTS" SHEET, LATEST EDITION, TRANSPORTATION DIVISION, PUBLIC WORKS DEPARTMENT.
4. THE WALK BETWEEN THE PAD AND CITY SIDEWALK SHALL BE PLACED TO THE LEFT END OF THE BUS PAD SHOWN UNLESS AN EXISTING OBSTACLE PROHIBITS PLACEMENT THERE.

Larry D. Pagel
 LARRY D. PAGEL
 DIRECTOR OF PUBLIC WORKS/CITY ENGINEER



DEPARTMENT OF
 PUBLIC WORKS

**BUS STOP SHELTER
 PAD**

SCALE: NONE
 REVISED: MAY 16, 2001
 DRAWN BY: STAFF
 APPROVED BY:

CST
 ST-11

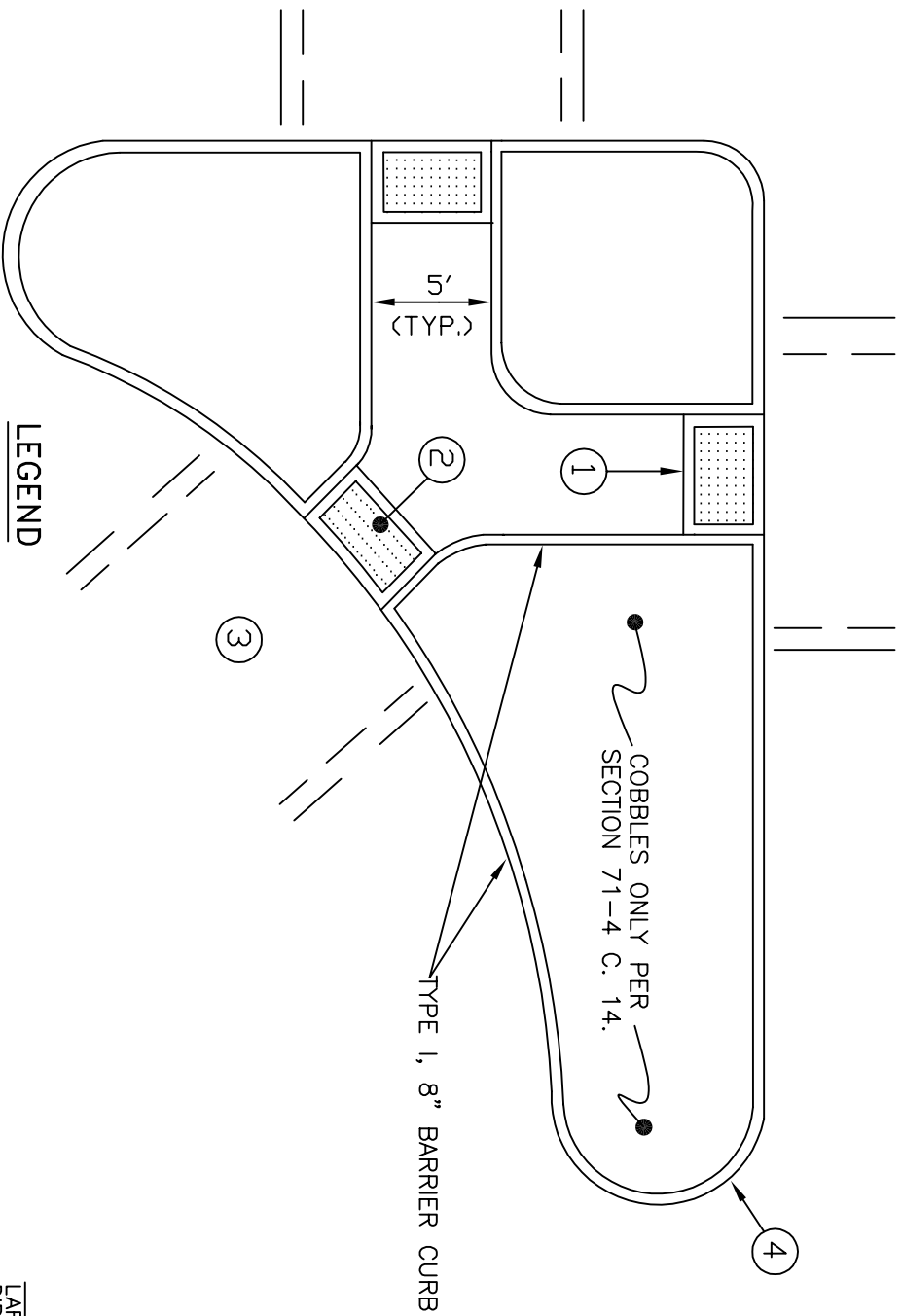

LEGEND

1. SAWCUT AND PLACE 5 FOOT X 4 FOOT X 6 INCH DEEP CONCRETE PAD. USE CLASS A 6 SACK CONCRETE. EMBED TRUNCATED DOME PANEL PER ITEM 2 BELOW (TYPICAL). 1% TO 2% GRADE SHALL BE MAINTAINED PER THE PLANS
2. 3 FOOT X 4 FOOT DETECTABLE WARNING PANEL PER SECTION 71-5 F. OF THESE SPECIFICATIONS. PANEL FLAT SURFACE SHALL BE FLUSH WITH CONCRETE AND ADJACENT AC. CONCRETE BORDER AROUND PANEL SHALL BE SIX INCHES WIDE. (TYPICAL)
3. CROSSWALK (TYPICAL)
4. FACE OF EIGHT INCH BARRIER CURB, PAVEMENT EDGE. (TYPICAL)

 LARRY D. PAGEL
 DIRECTOR OF PUBLIC WORKS/CITY ENGINEER



DEPARTMENT OF
 PUBLIC WORKS

TRAFFIC ISLAND
DETECTABLE WARNING SURFACE

SCALE: NONE
 REVISED: MAY 16, 2001
 DRAWN BY: STAFF
 APPROVED BY: LARRY D. PAGEL

CST
 ST-12

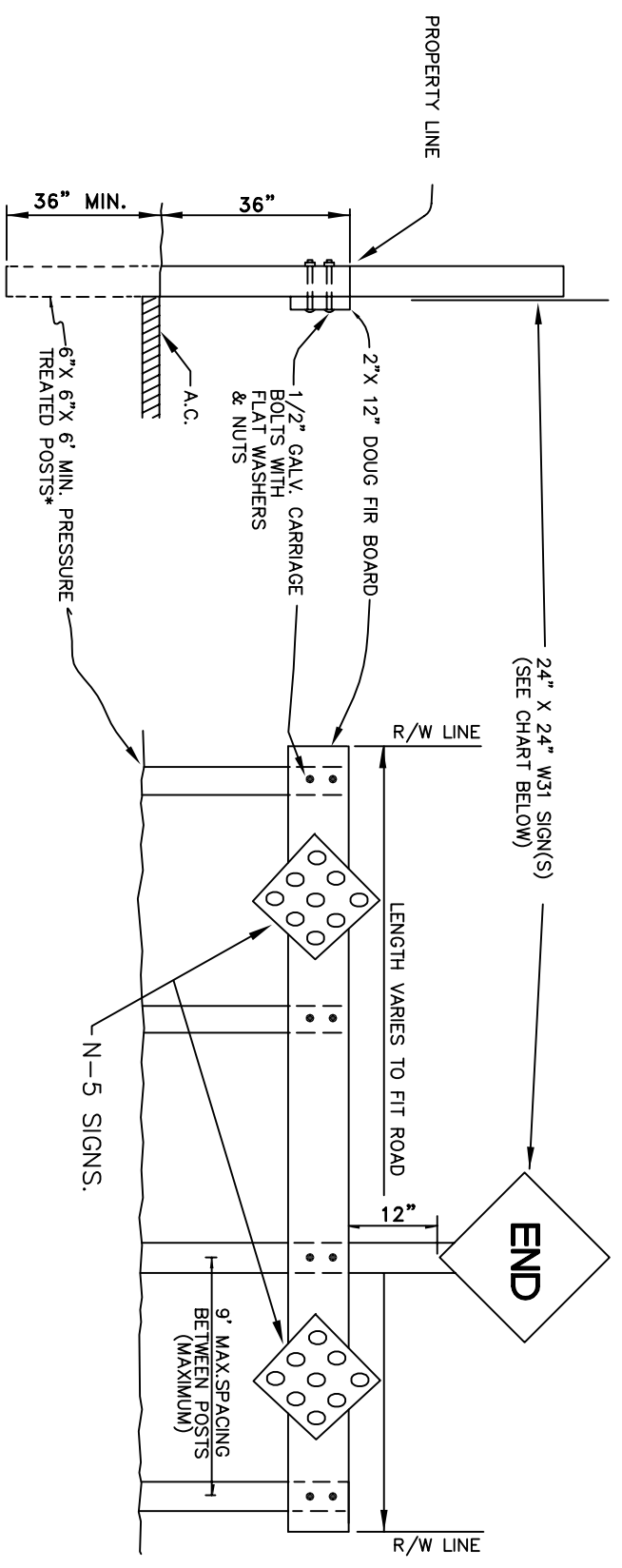

NUMBER AND SIZE OF SIGNS

R/W WIDTH	W31 SIGN SIZE	W31 SIGN NO.	C2 SIGN SIZE	C2 SIGN NO.
50' & 54'	24"	1	48" X 30"	1
60' & 66'	24"	2	48" X 30"	1
84' & 110'	24"	2	48" X 30"	2

NOTES:

1. WHERE PERMISSION HAS BEEN GRANTED TO CLOSE AN EXISTING PUBLIC STREET, A C2 "ROAD CLOSED" SIGN WILL BE REQUIRED ON THE CENTERLINE OF THE ROAD IN ADDITION TO THE W31 "END" SIGNS.
2. ALL EXPOSED SURFACES SHALL BE PAINTED WITH 2 (TWO) COATS OF WHITE PAINT CONFORMING TO SECTION 91-3.02 OF THE STATE SPECIFICATIONS.
3. ALL SIGNS SHALL BE 0.080 GA ALUMINUM.

LARRY D. PAGEL
DIRECTOR OF PUBLIC WORKS/CITY ENGINEER





DEPARTMENT OF PUBLIC WORKS

**STREET CLOSURE
TIMBER BARRICADE**

SCALE: NONE
REVISED: MAY 16, 2001
DRAWN BY: STAFF
APPROVED BY: LARRY D. PAGEL

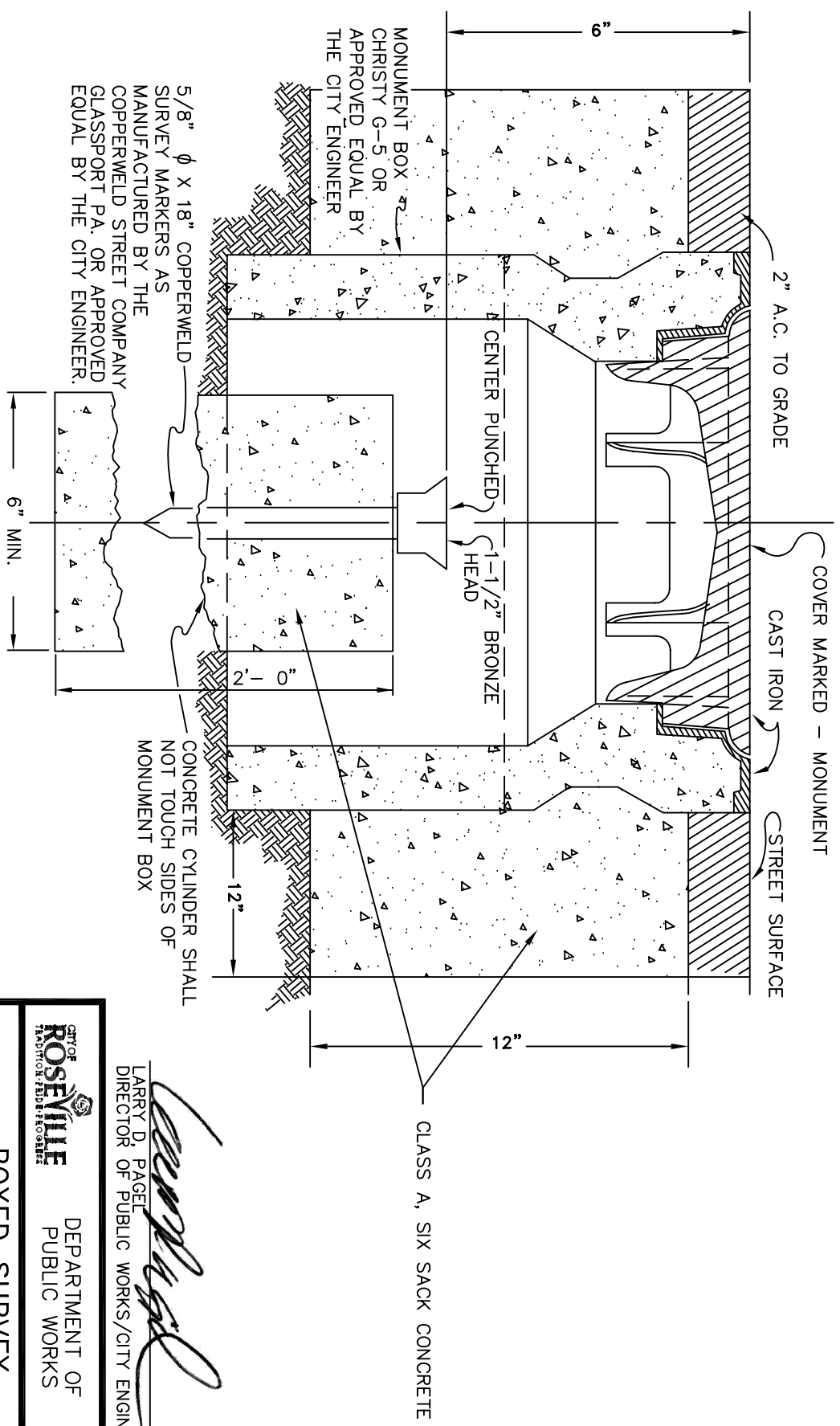
**CST
ST-13**



MONUMENT BOX
 CHRISTY G-5 OR
 APPROVED EQUAL BY
 THE CITY ENGINEER

5/8" ϕ X 18" COPPERWELD
 SURVEY MARKERS AS
 MANUFACTURED BY THE
 COPPERWELD STREET COMPANY
 GLASSPORT PA. OR APPROVED
 EQUAL BY THE CITY ENGINEER.

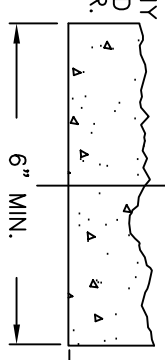

CONCRETE CYLINDER SHALL
 NOT TOUCH SIDES OF
 MONUMENT BOX

CLASS A, SIX SACK CONCRETE

Larry D. Pagel
 LARRY D. PAGEL
 DIRECTOR OF PUBLIC WORKS/CITY ENGINEER



DEPARTMENT OF
 PUBLIC WORKS

**BOXED SURVEY
 MONUMENT**

SCALE: NONE
 REVISED: MAY 16, 2001
 DRAWN BY: STAFF
 APPROVED BY: LARRY D. PAGEL

CST
 ST-15

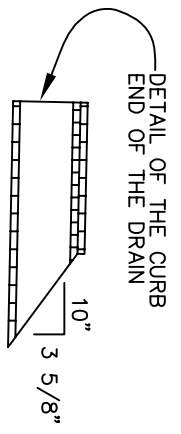

SECTION A-A
FOR TYPE 1 CURB

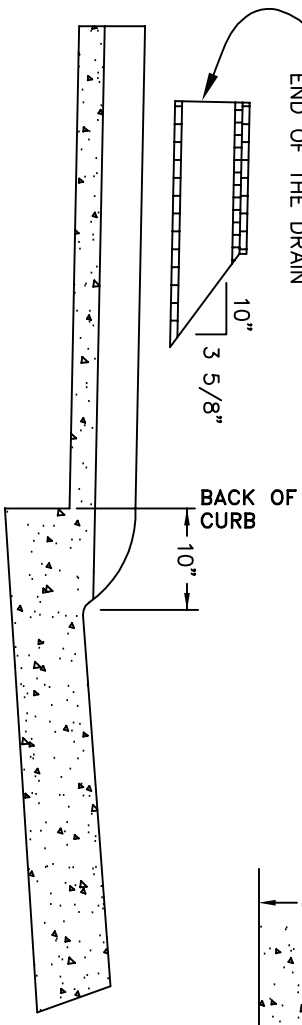

(FOR TYPE II CURB & GUTTER, ASSEMBLY SHALL MATCH CURB BATTER)

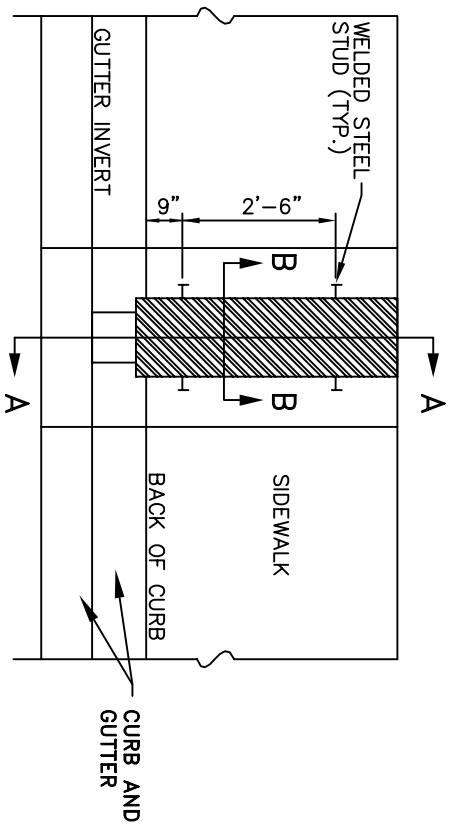

PLAN VIEW OF CURB, GUTTER & SIDEWALK

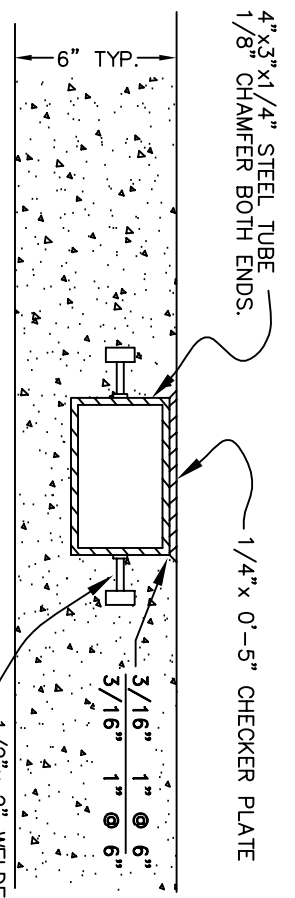

SECTION B-B

WHEN PLACING IN EXISTING SIDEWALK, SAWCUT AND REPLACE A LENGTH OF CURB, GUTTER AND SIDEWALK EQUAL TO THE SIDEWALK WIDTH. IF THE ASPHALT CONCRETE EDGE IS DAMAGED, SAWCUT THE PAVEMENT AND PAVE A TWO FOOT WIDE BY SIX INCH DEEP PATCH AT THE GUTTER LIP.

ALL HARDWARE SHALL BE GALVANIZED PER CALTRANS SPECIFICATIONS.

Larry D. Pagel
LARRY D. PAGEL
DIRECTOR OF PUBLIC WORKS/CITY ENGINEER



DEPARTMENT OF
PUBLIC WORKS

UNDER WALK DRAIN

SCALE: NONE
REVISED: MAY 16, 2001
DRAWN BY: STAFF
APPROVED BY: LARRY D. PAGEL

CST
ST-16

TABLE 1

APPROACH SPEED (MPH)	TAPER LENGTH (L)*	NUMBER OF CONES FOR TAPER*	SPACING OF CONES ALONG TAPER (FEET) ±
25	125	6	25
30	180	7	30
35	245	8	35
40	320	9	40
45	540	13	45
50	600	13	50
50+	1000	21	50

(*) BASED ON 12 FT. WIDE LANE. THIS COLUMN IS ALSO APPROPRIATE FOR LANE WIDTHS LESS THAN 12 FT.

LEGEND:

- SIGN
- CONE OR PORTABLE DELINEATOR
- DIRECTION OF TRAFFIC
- ◻ FLASHING ARROW SIGN (OPTIONAL)

NOTES:

TAPER FORMULA:

L = S x W FOR SPEEDS OF 45 OR MORE
 L = WS² FOR SPEEDS OF 40 OR LESS.
 60

WHERE:

- L = MINIMUM LENGTH OF TAPER.
- S = NUMERICAL VALUE OF POSTED SPEED LIMIT PRIOR TO WORK OR 85 PERCENTILE SPEED.
- W = WIDTH OF OFFSET.

NOTES:

1. THIS PLAN DOES NOT APPLY WHERE THERE ARE EMERGENCY CONDITIONS. UNDER EMERGENCY CONDITIONS, EQUIPMENT AND PERSONNEL WHICH ARE AVAILABLE SHOULD BE UTILIZED TO IMPLEMENT A CLOSURE, EVEN THOUGH SUCH CLOSURE DOES NOT MEET THE STANDARDS CONTAINED IN THIS PLAN. AS EQUIPMENT OR PERSONNEL BECOME AVAILABLE, AN IMMEDIATE EFFORT SHOULD THEN BE MADE TO IMPLEMENT THE STANDARDS SHOWN ON THIS PLAN.
2. WHERE APPROACH SPEEDS ARE LOW, SIGNS MAY BE PLACED AT 300 FOOT SPACINGS, AND EVEN CLOSER IN URBAN AREAS.
3. ALL ADVANCE WARNING SIGNS SHALL BE 36" x 36" MINIMUM. (SEE NOTE 5).
4. ALL WARNING SIGNS FOR NIGHT CLOSURES SHALL BE EITHER ILLUMINATED OR REFLECTORIZED.
5. A "C18 ROAD CONSTRUCTION AHEAD" SIGN MAY BE USED IN LIEU OF THE C23. (SEE NOTE 3).
6. A "C13 END CONSTRUCTION" SIGN, AS APPROPRIATE, MAY BE USED IN LIEU OF THE C14. THE SIGN IS OPTIONAL IF THE END OF WORK ZONE IS OBVIOUS OR FALLS WITHIN A LARGER PROJECT LIMIT.
7. WARNING (W) SERIES SIGNS USED IN WORK ZONES SHALL BE BLACK OR ORANGE. EXISTING YELLOW PAINTING MARKINGS FOR CLOSURES SHALL CONFORM TO SECTION 5-05 OF THIS MANUAL.
8. WARNING MARKINGS FOR CLOSURES SHALL CONFORM TO SECTION 5-05 OF THIS MANUAL.
9. ALL CONES SHALL BE INTERNALLY ILLUMINATED OR FITTED WITH REFLECTIVE WHITE SLEEVES FOR NIGHT CLOSURES (SEE SECTION 5-03.3).
10. THE MAXIMUM SPACING BETWEEN CHANNELIZING DEVICES IN A TAPER SHOULD BE APPROXIMATELY EQUAL IN FEET TO THE SPEED LIMIT. (SEE TABLE 1).

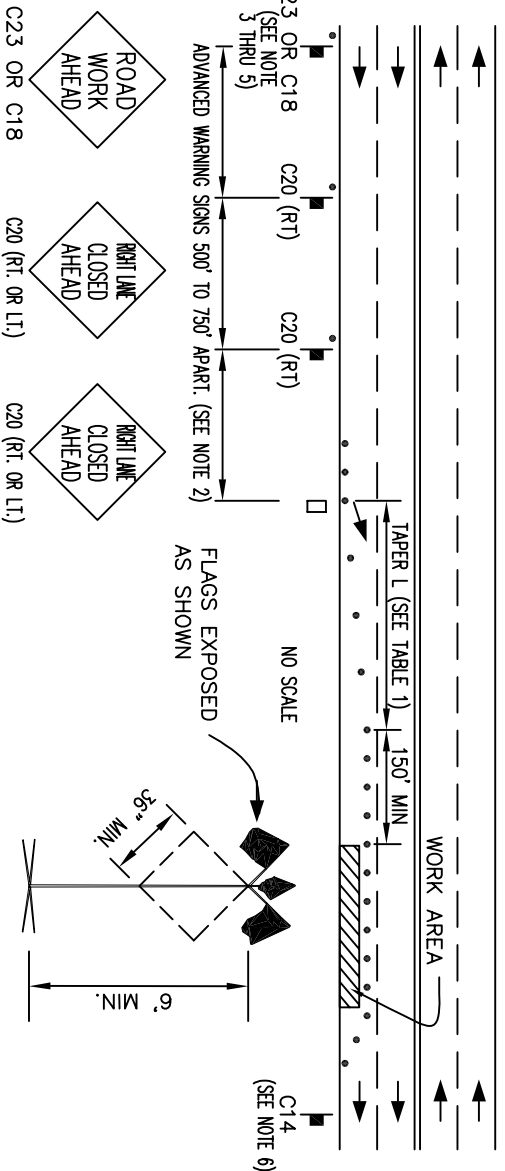

SPECIAL NOTES:

THIS DETAIL IS REPRODUCED FROM FIGURE 5-9 OF THE STATE OF CALIFORNIA MANUAL OF TRAFFIC CONTROLS FOR CONSTRUCTION AND MAINTENANCE WORK ZONES. FIELD CONDITIONS COULD REQUIRE DEVIATIONS FROM THESE PLANS AND ACCOMPANYING NOTES. SEE SECTION 21-2 OF CITY OF ROSEVILLE STANDARDS FOR CONES AND DELINEATORS.

Larry D. Pagel
 LARRY D. PAGEL
 CITY ENGINEER/DIRECTOR OF PUBLIC WORKS



DEPARTMENT OF
 PUBLIC WORKS

**TYPICAL TRAFFIC CONTROL
 LANE CLOSURE/TRANSITION**

SCALE: NONE
 REVISED: MAY 16, 2001
 DRAWN BY: STAFF
 APPROVED BY: LARRY D. PAGEL

CST
 ST-17

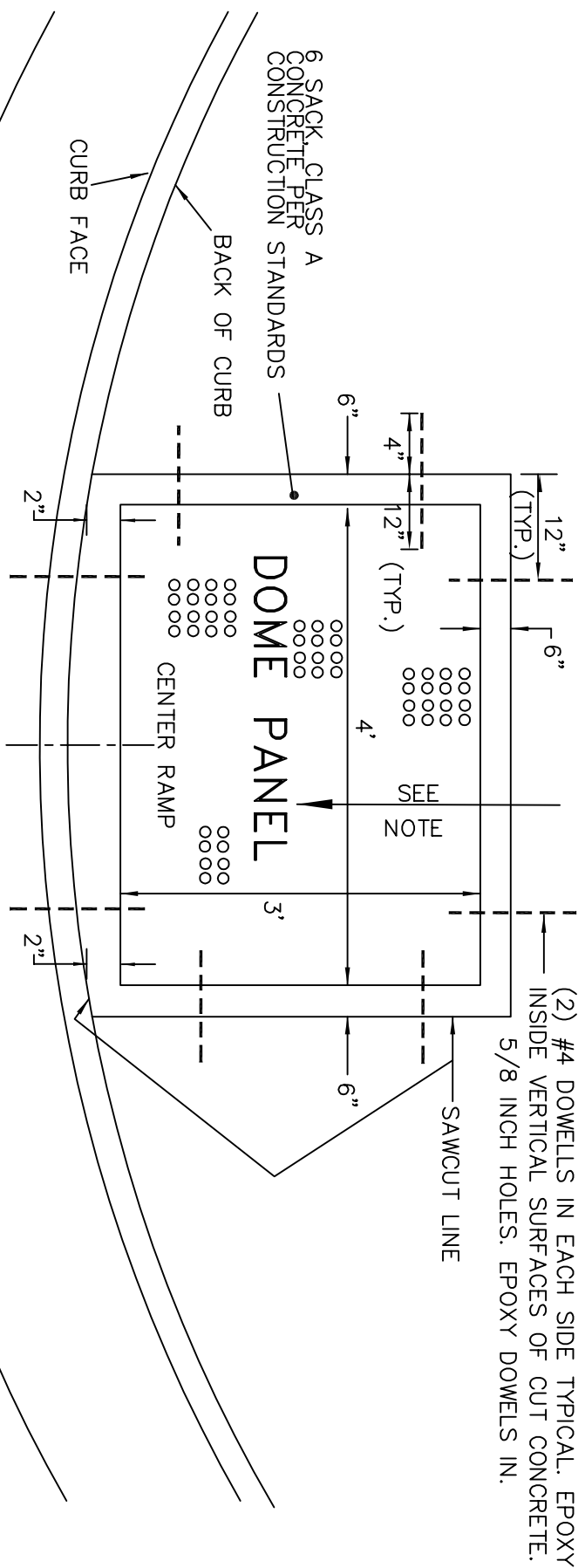

NOTE:
 PRIOR TO RETROFITTING TRUNCATED DOME PANEL,
 ASSURE GRADES CONFORM TO CITY REQUIREMENTS.

Larry D. Pagel
 LARRY D. PAGEL
 DIRECTOR OF PUBLIC WORKS/CITY ENGINEER



DEPARTMENT OF
 PUBLIC WORKS

DETECTABLE WARNING
 (TRUNCATED DOME PANEL)
 RETROFIT OR REPLACEMENT

SCALE: NONE
 REVISED: MAY 16, 2001
 DRAWN BY: STAFF
 APPROVED BY:

CST
 ST-18